

Magnetic Float Switches 1003

Magnetic Float Switches 1003

Table of contents

Index

Table of contents	40
Description and function	41
Certificates / Approvals	42-43
Magnetic Float Switches 1003	
Stainless steel DN10 to DN500	44
Brass DN10 to DN500	45
Titanium DN10 to DN500	46
Alloy DN10 to DN500	47
PVC DN10 to DN500	48
PP DN10 to DN500	49
PVDF DN10 to DN500	50
Aceptic design / Electrolytically polished	51
Food design / Sanitary-Standard 3A	52
Brass and stainless steel with polyamide flange	53
Brass and stainless steel adjustable design	54
Stainless steel and brass in angled design for side installation	55
E-CTFE and PFA coated stainless steel design	56
Polyamide and stainless steel in flexible design	57
PP and PVDF in flexible design	58
Stainless steel and brass test function design	59
Stainless steel with bypass housing	60
Gunmetal and Aluminium with bypass housing	61
SNU-safety switch	62
For bulk material and viscous media	63
Spherical float with axial-magnetic system	64
Immersion depth-diagram	65-67
Spherical float with axial-magnetic system	
Cylindrical float with axial-magnetic system	68
Immersion depth-diagram	69-70
Cylindrical float with axial-magnetic system	
Type key	71-73
Electrical connections	74-75
Design process connections	76-78
Contact functions / Temperature probe	79
Cable / Materials	80

Instructions for instrument selection in the catalogue

So that the customer gets the best equipment solution according to his requirements, we recommend this simple procedure using the following pages:

- Define the dimension of the fitting or interface (e.g. thread G2", DIN-flange DN25/PN16, etc.)
- Determine the electrical connection (e.g. terminal box, cable entry, plug, etc.)
- Find out the operating conditions, min. and max. operating pressure, temperature and specific gravity of the media at the max. operating temperature.
- With the size of the fitting and material of the instrument, a guide specification can be selected on pages 44 to 63.
- The full and final specification can now be generated by reference to the „type key“ on pages 71 to 73.
- With the type description and the technical operating conditions a price quotation can be made or the instrument can be ordered.
- Specification of the requested approval.

Magnetic Float Switches 1003

Description and function

Magnetic float switches work according to the float principle with magnetic transmission (permanent magnet / reed switch).

A magnet, which is built in the float actuates with its magnetic field, through the wall of the guide tube, one or more reed contacts.

By this way, volt-free opening, closing or change-over functions can be reached. Magnetic float switches are suitable for almost every liquid mediums e.g. full or empty detector, to control pumps or valves or to signal filling levels. By the volt-free reed contacts, the magnetic float switches are an ideal switching element in connection with PLC controls.

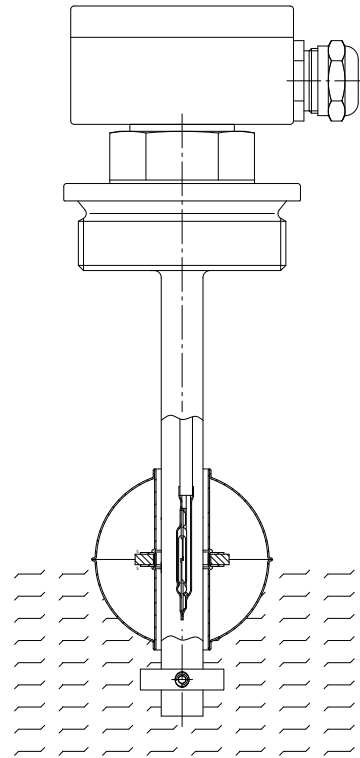

Additional installation / important notes

1. Contact protection

In the chapter 1011 you can find different contact protection relays. In connection with these instrument, the contacts of the magnetic float switches are only loaded by the smallest current and voltage.

2. Material

In the catalogue you find common materials such as stainless steel, brass, titanium, alloy, plastics or coatings. We also manufacture instruments in other materials on request.

3. Mounting note

The magnetic float switches can also be installed in the bottom of a container, e.g. type EVR-VS-L... -SV-1PVC changes to UEVR-VS-L... -SV-1PVC.

4. Definition of switching functions

The required switching functions will be produced on rising level on the defined level height.

5. Special designs

In this chapter 1003, you find approx. 50 versions as magnetic float switches can be constructed. As an innovative manufacturer we are always in the position to produce a customer-specific instrument, exactly as per your ideas.

Our performance and innovation readiness is always to see in connection with highest quality thoughts. With the confidence of our customers we have become to a leading manufacturer of level control instruments. Together we have developed the best solutions. Progress by innovation is only possible by close customer bond.

6. Manufacturing of bolts or float stoppers

Magnetic float switches will be equipped, depending on design, not with float limiting rings (float stoppers) but with welded bolts.

7. Temperature contacts and temperature probes

Technical data about temperature contacts and temperature probes you find on page 79.

Magnetic Float Switches 1003

Certificates / Approvals

Certificates



SCHWEIZERISCHER VEREIN FÜR QUALITÄTS- UND MANAGEMENTSYSTEME

Certified according to ISO 9000 rev. 2000



SWISS TECHNICAL SERVICES AG

Approval as production factory, welding examination and procedure qualification incl. restamping certificate for the production of pressure tanks according to SVTI-regulation 501, 201

Approvals

The company Heinrich Kübler AG can manufacture magnetic float switches to most national and industrial approvals. Therefore a wide range of instruments with approvals requirements can be produced according to customer's requests.



TECHNISCHER ÜBERWACHUNGSVEREIN DEUTSCHLAND (PED)

Approval as production factory for manufacture of pressure tanks according to AD HP 0, PED Pressure Equipment Directive 97/23/EG



SOCIETE NATIONALE DE CERTIFICATION ET D'HOMOLOGATION (ATEX)

Approval for the production of Magnetic Float Switches according to EU-Directive 94/9/EG



DEUTSCHES INSTITUT FÜR BAUTECHNIK DIBT (WHG)

Approval according to water regime law WHG



GERMANISCHER LLOYD (Building of ships)

Approval for the production of Magnetic Float Switches according to GL-regulations



BUREAU VERITAS (Building of ships)

Approval for the production of Magnetic Float Switches according to BV-regulations



REGISTRO ITALIANO NAVALE (Building of ships)

Approval for the production of Magnetic Float Switches according to RINA-regulations



3A - Sanitary Standards (Dairy equipment)

Approval for the production of Magnetic Float Switches according to 3A-regulations

Magnetic Float Switches 1003 Approvals

As an innovative manufacturer of instruments for level control, we can offer to our customers systems according to different directives. The types of approval, applications and limits of use can be taken from the following specifications.

Approvals

Ex

A large number of magnetic float switches from our standard range, or to customer requests, can be built according to the EU-Directive 94/9/EG with the protection types EEx ia IIC T3 to T6, EEx d T4 to T6 or dust Ex/D. By the combination of the instruments with the type key the catalogue shows with the Ex hexagonal logo which components can be used for Ex-instruments.

Temperatures of media:

EEx ia-instruments

T3	180 °C
T4	130 °C
T5	95 °C
T6	80 °C

EEx d-instruments

T4	120 °C
T5	95 °C
T6	80 °C

Electrical limit values:

Depending on applications

Type apparent on type plate, installation and operating manual

PED

Under the Pressure Equipment Directive 97/23/EG, any pressure vessel or instrument used within a pressurised system at 0,5 bar or above, has to conform to various categories. Depending on the design data or customer needs, manufacture of instruments is to either of the categories below.

Category II

Module	A1
--------	----

Category IV

Module	B+D
--------	-----

WHG

The WHG-approval prescribes us, how safety overflow switches must be built for the storage of water-endangering liquids in containers and tanks. We have the possibility of building a large range of level sensors to the standard WHG §19.

GL / BV / RINA

Magnetic Float Switches for use in shipping can be manufactured to GL (Germanischer Lloyd), BV (Bureau Veritas) or RINA (Registro Italiano Navale) standards in large variety of design possibilities complete with controllers.

Magnetic Float Switches 1003

Stainless steel DN10 to DN500

Technical data

Guide tube diameter:	8 mm length to 1000 mm 10 mm length to 2000 mm 12 mm length to 5000 mm	14 mm length to 5000 mm 18 mm length to 6000 mm
Connection sizes / guide tube:	Thread BSP 1/8" ... Ø8 mm Thread BSP 3/8" ... Ø10 ... 14 mm Thread BSP 1/2" ... Ø18 mm Flange DIN DN25 ... Ø 8 mm Flange DIN DN40 ... Ø10 ... 14 mm Flange DIN DN80 ... Ø18 mm	Thread NPT 1/8" ... Ø8 mm Thread NPT 3/8" ... Ø10 ... 14 mm Thread NPT 1/2" ... Ø18 mm Flange ANSI 1" ... Ø8 mm Flange ANSI 1 1/2" ... Ø10 ... 14 mm Flange ANSI 3" ... Ø18 mm
Contacts:	U - change over S - normally open O - normally closed	
Temperature contacts:	TO ... °C normally closed TS ... °C normally open	
Temperature probe:	PT- 100 (optional with control unit) PT-1000 (optional with control unit)	
Float:	See float table pages 64-70	
Approvals:	See approvals pages 42-43	
Operating parameters:	Temperature: -30 °C ... +200 °C Pressure: -1 .. 175 bar Specific gravity: ≥400 kg/m ³	

Thread with cable type E ...

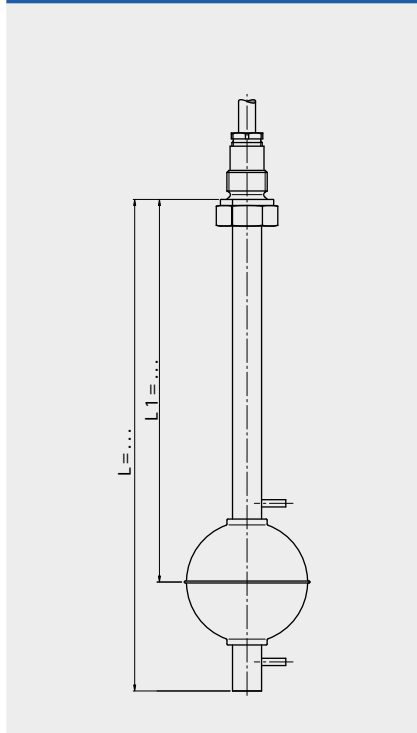

Thread with terminal box type A ...

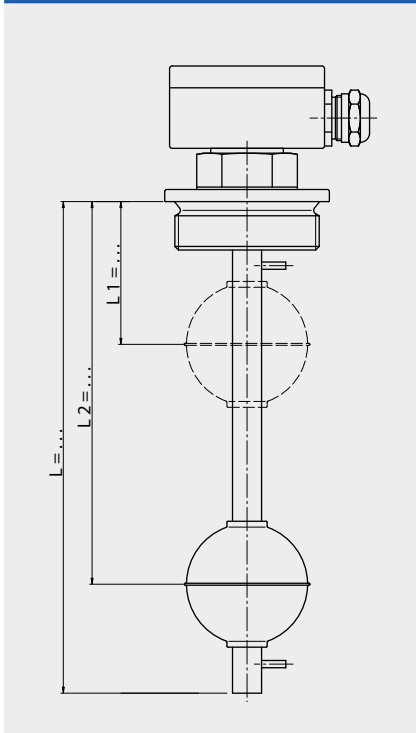

Flange with plug type AS ... F

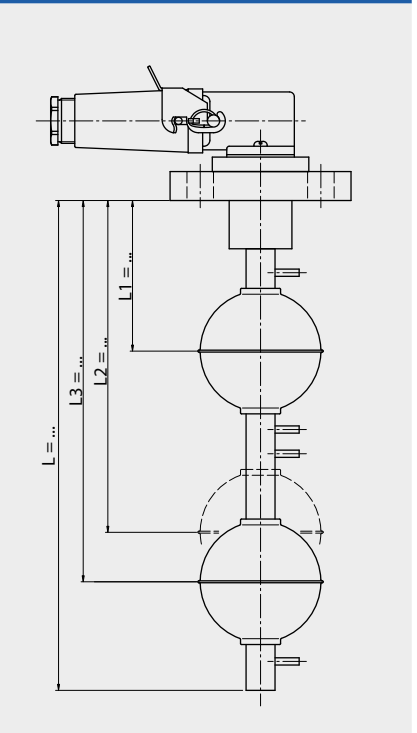

Type combination see type key Magnetic Float Switches

Magnetic Float Switches 1003

Brass DN10 to DN500

Technical data		
Guide tube diameter:	8 mm length to 1000 mm 12 mm length to 5000 mm	14 mm length to 5000 mm 18 mm length to 6000 mm
Connection sizes / guide tube:	Thread BSP 1/8" ... Ø8 mm Thread BSP 3/8" ... Ø10 ... 14 mm Thread BSP 1/2" ... Ø18 mm	Thread NPT 1/8" ... Ø8 mm Thread NPT 3/8" ... Ø10 ... 14 mm Thread NPT 1/2" ... Ø18 mm
Contacts:	U - change over S - normally open O - normally closed	
Temperature contacts:	TO ... °C normally closed TS ... °C normally open	
Temperature probe:	PT- 100 (optional with control unit) PT-1000 (optional with control unit)	
Float:	See float table pages 64-70	
Approvals:	See approvals pages 42-43	
Operating parameters:	Temperature: -10 °C ... +150 °C Pressure: -1 ... 16 bar Specific gravity: ≥400 kg/m³	

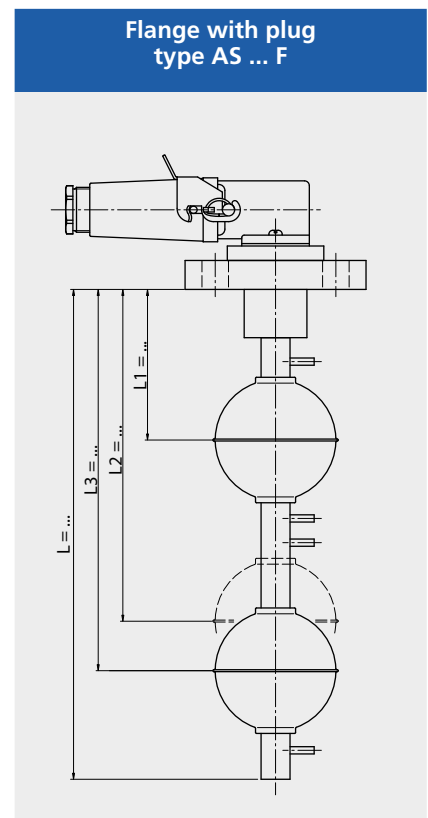
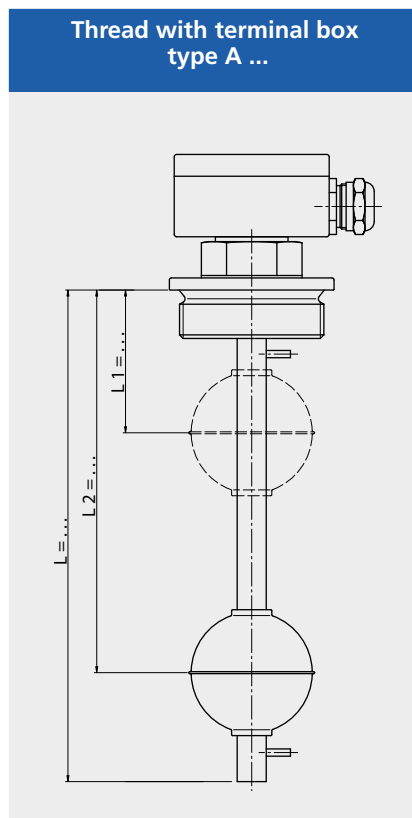
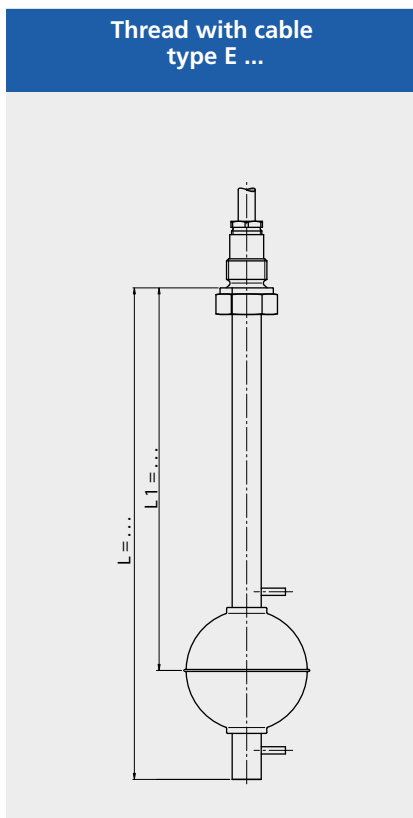

Type combination see type key Magnetic Float Switches

Magnetic Float Switches 1003

Titanium DN10 to DN500

Technical data			
Guide tube diameter:	8 mm length to 1000 mm 10 mm length to 2000 mm 12 mm length to 5000 mm	14 mm length to 5000 mm 18 mm length to 6000 mm	
Connection sizes / guide tube:	Thread BSP 1/8" ... Ø8 ... 14 mm Thread BSP 1/2" ... Ø18 mm Flange DIN DN50 ... Ø8 ... 14 mm Flange DIN DN80 ... Ø18 mm	Thread NPT 1/8" ... Ø8 ... 14 mm Thread NPT 1/2" ... Ø18 mm Flange ANSI 2" ... Ø8 ... 14 mm Flange ANSI 3" ... Ø18 mm	
Contacts:	U - change over S - normally open O - normally closed		
Temperature contacts:	TO ... °C normally closed TS ... °C normally open		
Temperature probe:	PT- 100 (optional with control unit) PT-1000 (optional with control unit)		
Float:	See float table pages 64-70		
Approvals:	See approvals pages 42-43		
Operating parameters:	Temperature: -10 °C ... +150 °C Pressure: -1 ... 22 bar Specific gravity: ≥400 kg/m³		

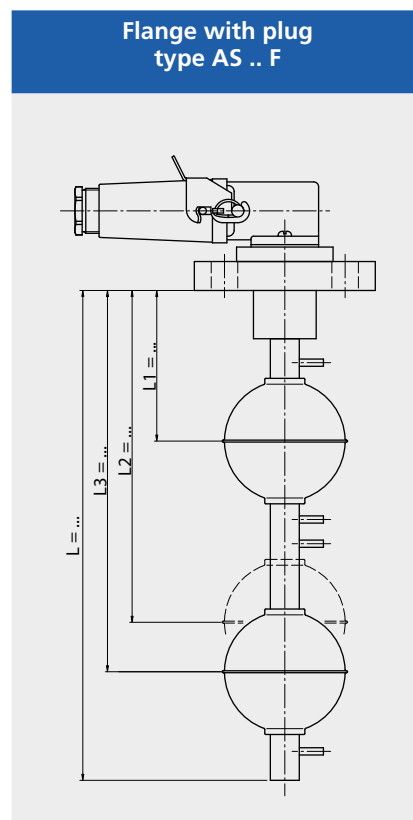
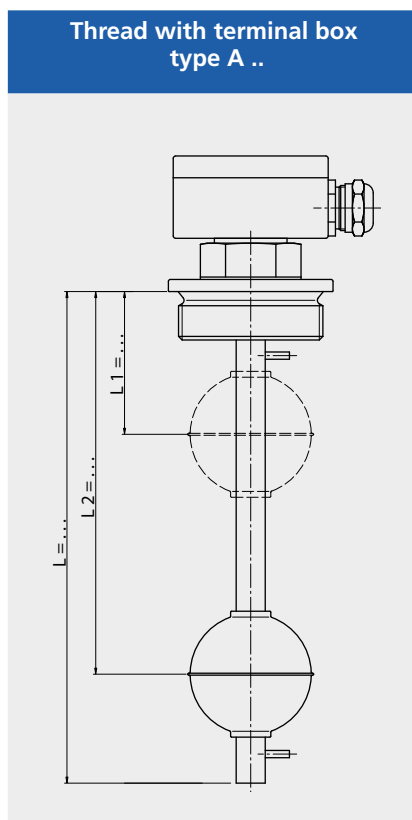
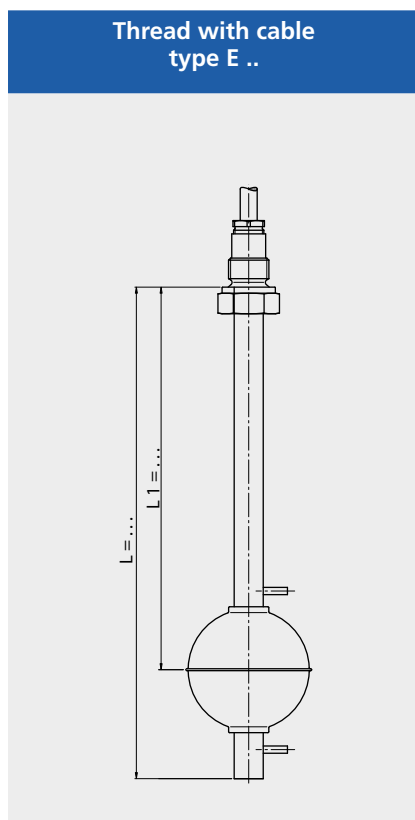

Type combination see type key Magnetic Float Switches

Magnetic Float Switches 1003

Alloy DN10 to DN500

Technical data		
Guide tube diameter:	10 mm length to 2000 mm 12 mm length to 5000 mm	14 mm length to 5000 mm 18 mm length to 6000 mm
Connection sizes / guide tube:	Thread BSP $\frac{3}{8}$ " ... $\varnothing 8$... 14 mm Thread BSP $\frac{1}{2}$ " ... $\varnothing 18$ mm Flange DIN DN50 ... $\varnothing 10$... 14 mm Flange DIN DN80 ... $\varnothing 18$ mm	Thread NPT $\frac{3}{8}$ " ... $\varnothing 8$... 14 mm Thread NPT $\frac{1}{2}$ " ... $\varnothing 18$ mm Flange ANSI 2" ... $\varnothing 10$... 14 mm Flange ANSI 3" ... $\varnothing 18$ mm
Contacts:	U - change over S - normally open O - normally closed	
Temperature contacts:	TO ... °C normally closed TS ... °C normally open	
Temperature probe:	PT- 100 (optional with control unit) PT-1000 (optional with control unit)	
Float:	See float table pages 64-70	
Approvals:	See approvals pages 42-43	
Operating parameters:	Temperature: -30 °C ... +200 °C Pressure: -1 ... 55 bar Specific gravity: ≥ 500 kg/m ³	

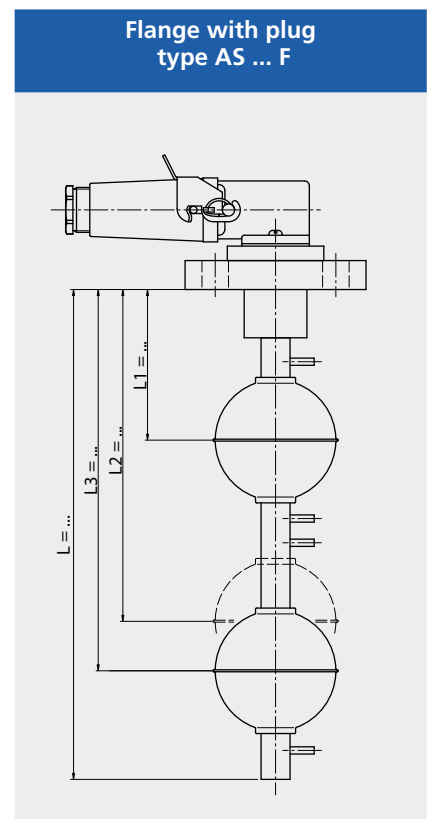
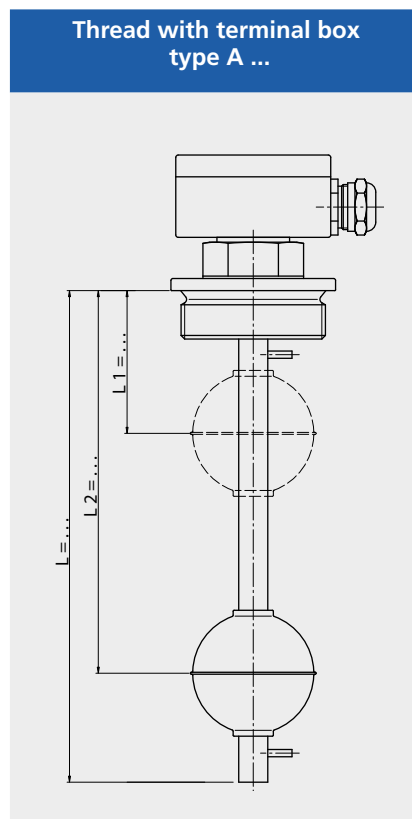
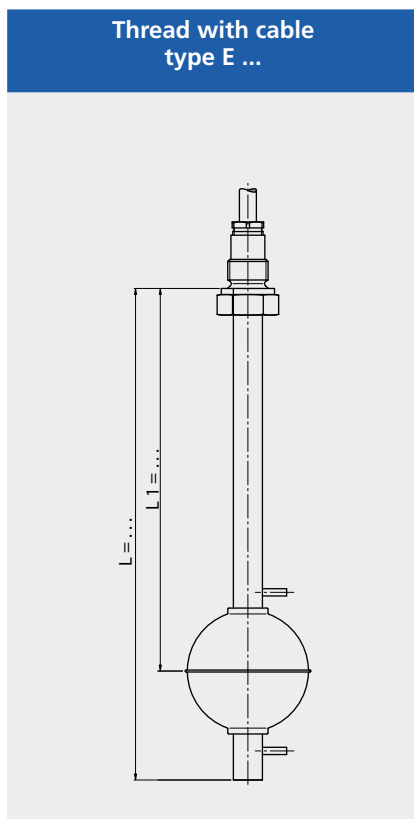

Type combination see type key Magnetic Float Switches

Magnetic Float Switches 1003

PVC DN10 to DN500

Technical data		
Guide tube diameter:	8 mm length to 800 mm 12 mm length to 800 mm	16 mm length to 4000 mm 20 mm length to 5000 mm
Connection sizes / guide tube:	Thread R 1/8" ... Ø8 ... 12 mm Thread BSP 1/2" ... Ø16 mm Thread BSP 1" ... Ø20 mm Flange DIN DN50 ... Ø8 ... 12 mm Flange DIN DN65 ... Ø16 mm Flange DIN DN80 ... Ø20 mm	Thread NPT 3/8" ... Ø8 ... 12 mm Thread NPT 1/2" ... Ø16 mm Thread NPT 1" ... Ø20 mm Flange ANSI 2" ... Ø8 ... 12 mm Flange ANSI 2 1/2" ... Ø16 mm Flange ANSI 3" ... Ø20 mm
Contacts:	U - change over S - normally open O - normally closed	
Temperature contacts:	TO ... °C normally closed TS ... °C normally open	
Temperature probe:	PT- 100 (optional with control unit) PT-1000 (optional with control unit)	
Float:	See float table pages 64-70	
Approvals:	See approvals pages 42-43	
Operating parameters:	Temperature: -10 °C ... +60 °C Pressure: -1 ... +1 bar Specific gravity: ≥500 kg/m³	

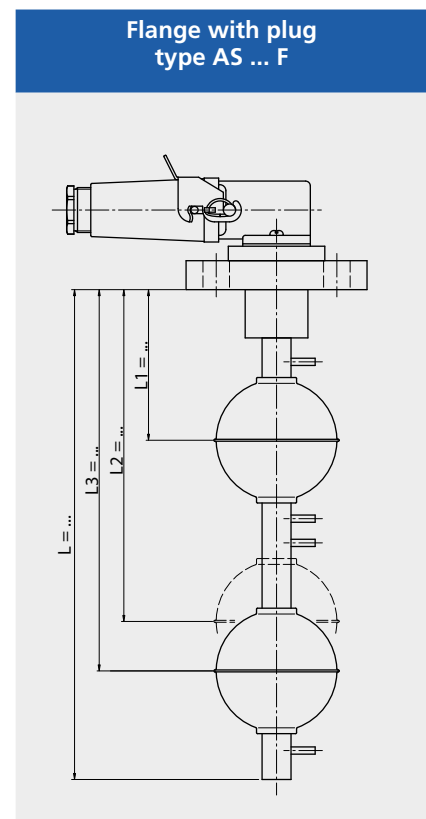
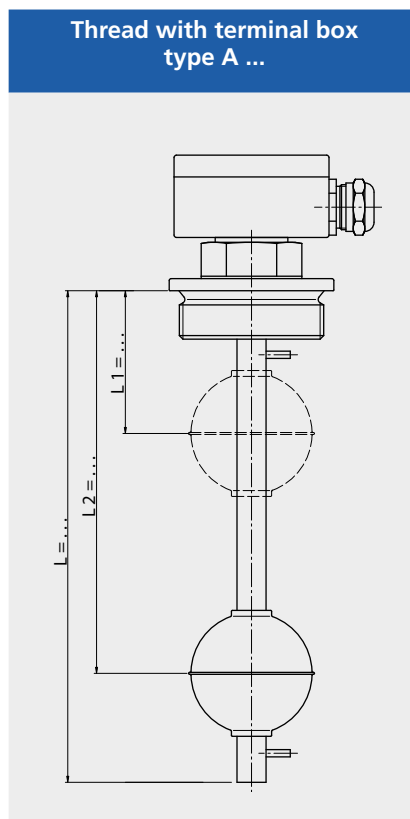
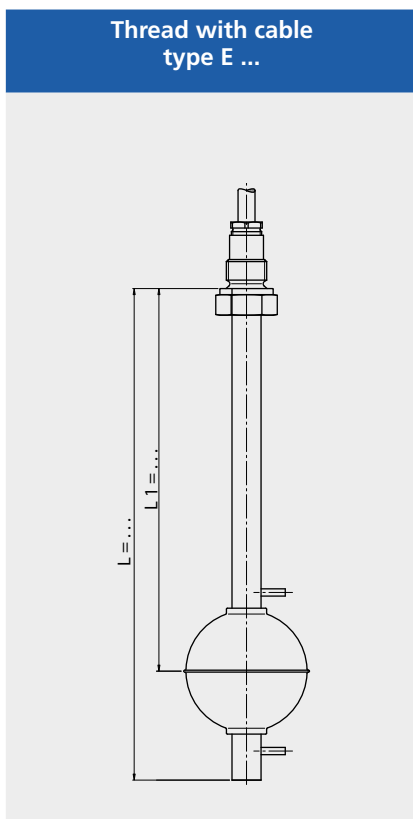

Type combination see type key Magnetic Float Switches

Magnetic Float Switches 1003

PP DN10 to DN500

Technical data

Guide tube diameter:	8 mm length to 800 mm 12 mm length to 800 mm	16 mm length to 4000 mm 20 mm length to 5000 mm
Connection sizes / guide tube:	Thread BSP 1/8" ... Ø8 mm Thread BSP 3/8" ... Ø12 mm Thread BSP 1/2" ... Ø16 mm Thread BSP 1" ... Ø20 mm Flange DIN DN25 ... Ø8 mm Flange DIN DN50 ... Ø12 mm Flange DIN DN65 ... Ø16 mm Flange DIN DN80 ... Ø20 mm	Thread NPT 1/8" ... Ø8 mm Thread NPT 3/8" ... Ø12 mm Thread NPT 1/2" ... Ø16 mm Thread NPT 1" ... Ø20 mm Flange ANSI 1" ... Ø8 mm Flange ANSI 2" ... Ø12 mm Flange ANSI 2 1/2" ... Ø16 mm Flange ANSI 3" ... Ø20 mm
Contacts:	U - change over S - normally open O - normally closed	
Temperature contacts:	TO ... °C normally closed TS ... °C normally open	
Temperature probe:	PT- 100 (optional with control unit) PT-1000 (optional with control unit)	
Float:	See float table pages 64-70	
Approvals:	See approvals pages 42-43	
Operating parameters:	Temperature: -5 °C ... +80 °C Pressure: -1 ... +1 bar Specific gravity: ≥500 kg/m³	

Thread with cable
type E ...



Thread with terminal box
type A ...

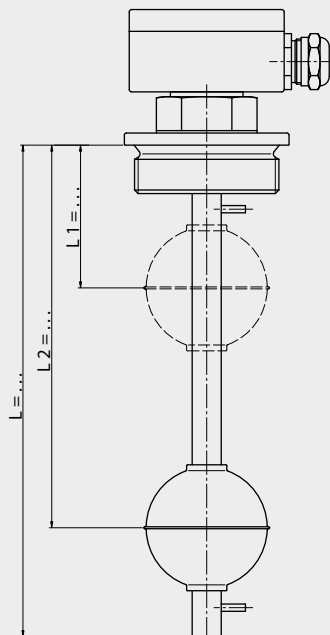

Flange with plug
type AS ... F

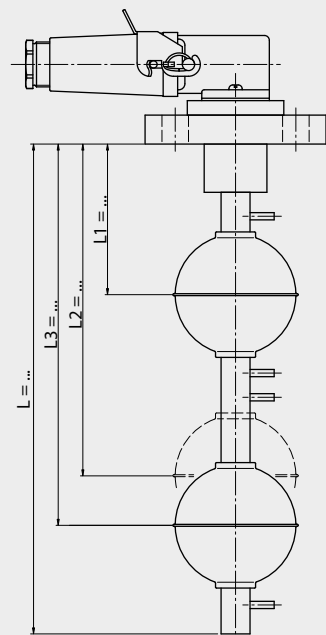

Type combination see type key Magnetic Float Switches

Magnetic Float Switches 1003

PVDF DN10 to DN500

Technical data			
Guide tube diameter:	12 mm length to 500 mm 16 mm length to 3000 mm	20 mm length to 5000 mm	
Connection sizes / guide tube:	Thread BSP 3/8" ... Ø12 mm Thread BSP 1/2" ... Ø16 mm Thread BSP 1" ... Ø20 mm Flange DIN DN50 ... Ø12 mm Flange DIN DN65 ... Ø16 mm Flange DIN DN80 ... Ø20 mm	Thread NPT 3/8" ... Ø12 mm Thread NPT 1/2" ... Ø16 mm Thread NPT 1" ... Ø20 mm Flange ANSI 2" ... Ø12 mm Flange ANSI 2 1/2" ... Ø16 mm Flange ANSI 3" ... Ø20 mm	
Contacts:	U - change over S - normally open O - normally closed		
Temperature contacts:	TO ... °C normally closed TS ... °C normally open		
Temperature probe:	PT- 100 (optional with control unit) PT-1000 (optional with control unit)		
Float:	See float table pages 68-70		
Approvals:	See approvals pages 42-43		
Operating parameters:	Temperature: -5 °C ... +100 °C Pressure: -1 ... +1 bar Specific gravity: ≥700 kg/m³		

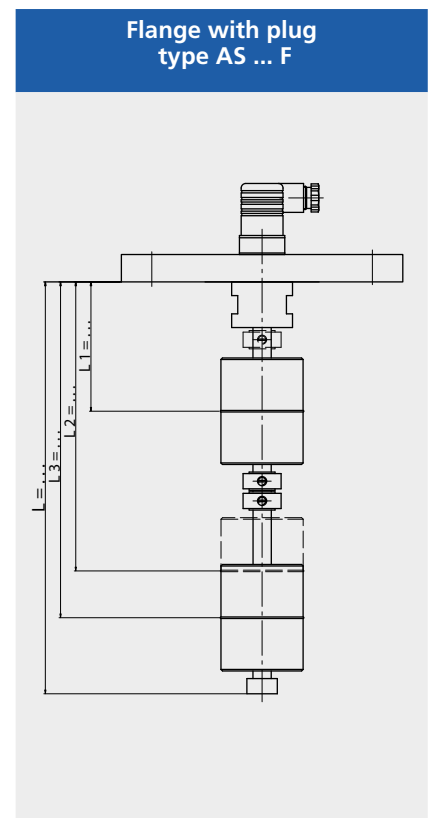
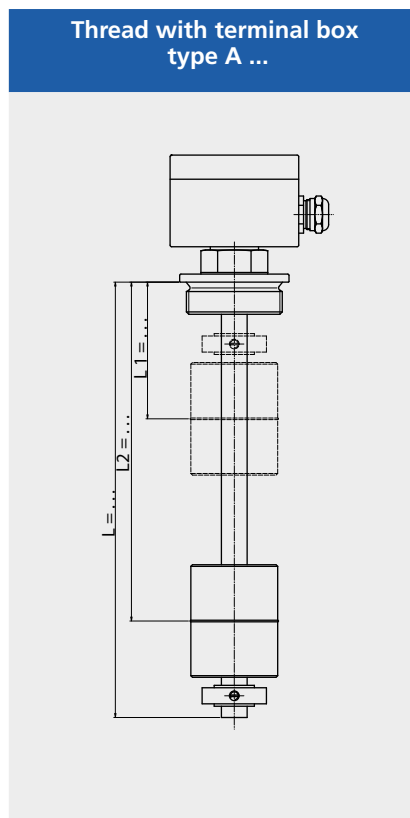
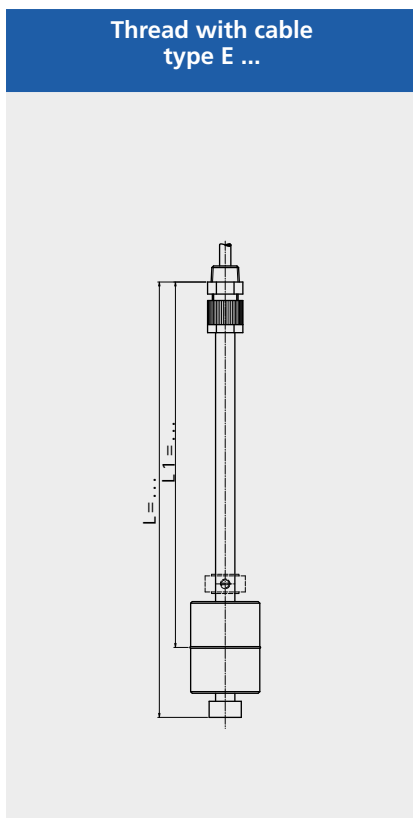

Type combination see type key Magnetic Float Switches

Magnetic Float Switches 1003

Aceptic design / Electrolytically polished

Technical data	
Guide tube diameter:	10 mm length to 2000 mm 12 mm length to 5000 mm 14 mm length to 5000 mm
Connection sizes:	Thread BSP 3/8" ... Tube connection according to DIN 11851 DN50 ... Tri-clamp connection 2" ...
Contacts:	U - change over S - normally open O - normally closed
Temperature contacts:	TO ... °C normally closed TS ... °C normally open
Temperature probe:	PT- 100 (optional with control unit) PT-1000 (optional with control unit)
Float:	See float table pages 64-70
Approvals:	See approvals pages 42-43
Operating parameters:	Temperature: -30 °C ... +200 °C Pressure: -1 ... 45 bar Specific gravity: $\geq 400 \text{ kg/m}^3$

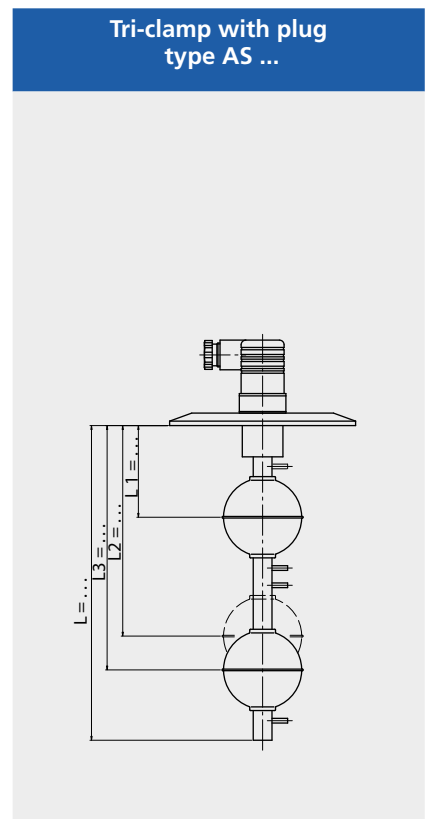
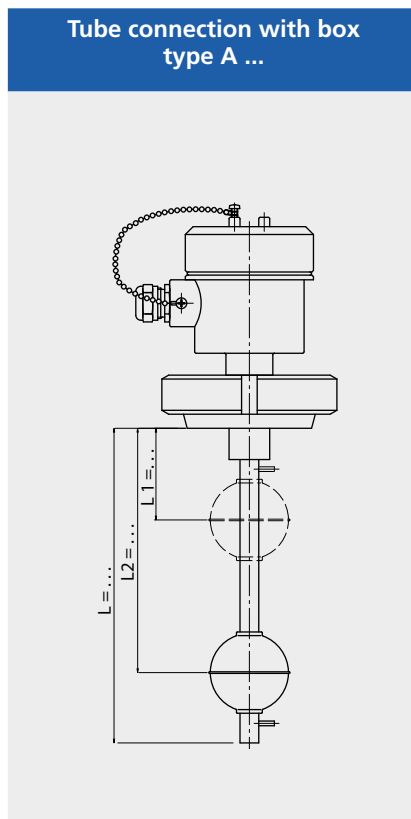
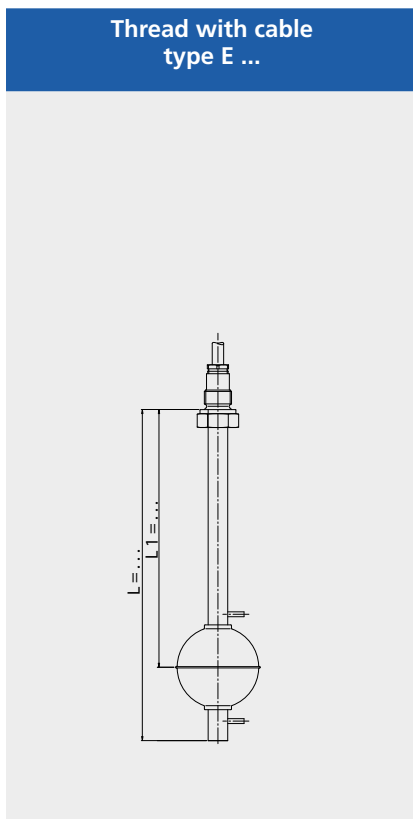

Type combination see type key Magnetic Float Switches

Magnetic Float Switches 1003

Food design / Sanitary-Standard 3A

Technical data	Stainless steel sanitary-standard 3A
Guide tube diameter:	16 mm length 200 ... 5000 mm
Connection sizes:	Thread BSP $\frac{3}{8}$ " Tube connection according to DIN 11851 NW100 ... Tri-clamp connection 4" ...
Contacts:	U - change over S - normally open O - normally closed
Temperature contacts:	TO ... °C normally closed TS ... °C normally open
Temperature probe:	PT- 100 (optional with control unit) PT-1000 (optional with control unit)
Float:	SV/80/3A
Approvals:	See approvals pages 42-43
Sanitary-Standard 3A:	Surface polished, surface finish 0.4µm
Operating parameters:	Temperature: -30 °C ... +200 °C Pressure: -1 ... 45 bar Specific gravity: $\geq 750 \text{ kg/m}^3$

Thread with cable
type E ...

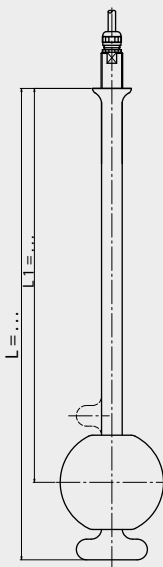

Thread with terminal box
type A ...

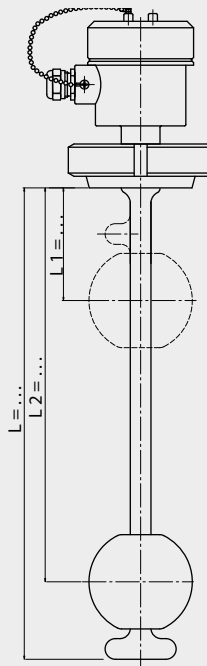

Tri-clamp with plug
type AS ...

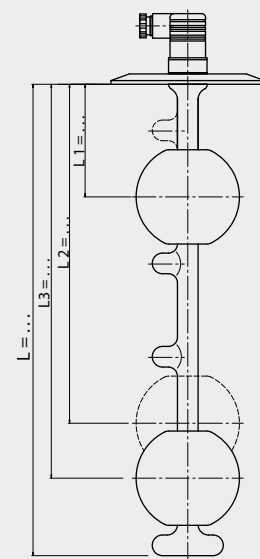

Type combination see type key Magnetic Float Switches

Magnetic Float Switches 1003

Stainless steel and Brass with polyamide flange

Technical data	Stainless steel / Brass
Guide tube diameter:	12 mm length to 5000 mm
Connection sizes:	Oval flange: 80x50 mm Hole spacing: 55 mm Hole diameter: 6.5 mm Material: polyamide
Connection plug:	Plug: Hirschmann acc.to DN 43650 3-pole Plug: HTS 6-pole Plug: W/HTS 6-pole
Contacts:	U - change over S - normally open O - normally closed
Temperature contacts:	TO ... °C normally closed TS ... °C normally open
Temperature probe:	PT- 100 PT-1000
Float:	See float table pages 68-70
Operating parameters:	Temperature: -10 °C ... +80 °C Pressure: -1 ... 1 bar Specific gravity: $\geq 700 \text{ kg/m}^3$

With Hirschmann plug
type AF-...

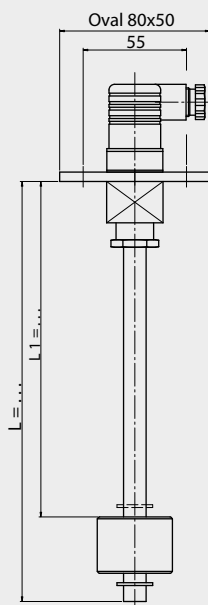

With HTS plug
type AF(HTS)-...

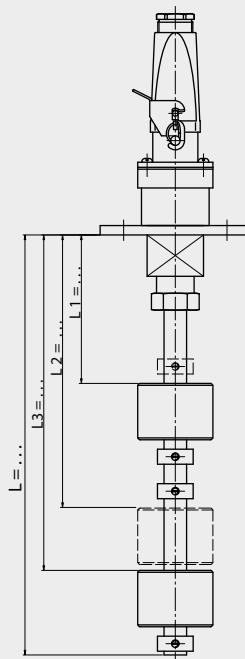

With W/HTS plug
type AF(W/HTS)-...

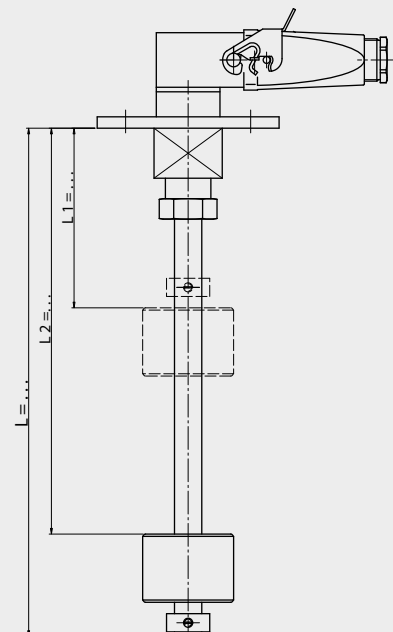

Type combination see type key Magnetic Float Switches

Magnetic Float Switches 1003

Stainless steel and Brass adjustable design

Technical data	Stainless steel / Brass
Guide tube diameter:	12 mm length to 5000 mm
Connection sizes:	Thread BSP 1/2" ... with locking ring Thread NPT 1/2" ... with locking ring
Contacts:	U - change over S - normally open O - normally closed
Temperature contacts:	TO ... °C normally closed TS ... °C normally open
Temperature probe:	PT- 100 (optional with control unit) PT-1000 (optional with control unit)
Float:	See float table pages 68-70
Operating parameters:	Temperature: -10 °C ... +150 °C Pressure: -1 ... 3 bar Specific gravity: $\geq 400 \text{ kg/m}^3$

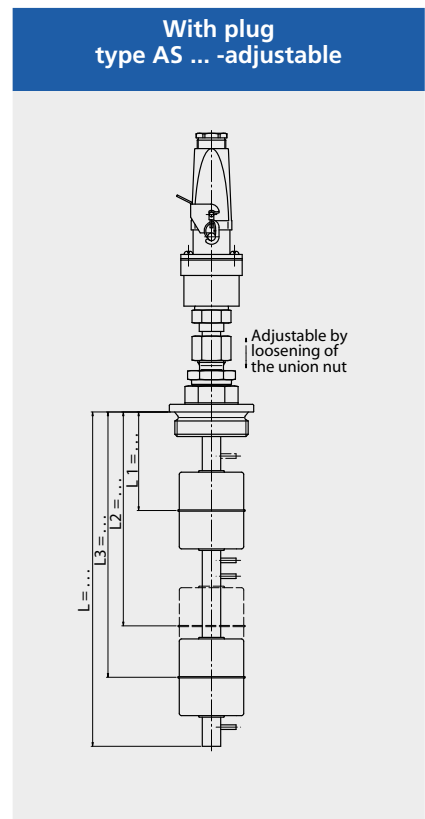
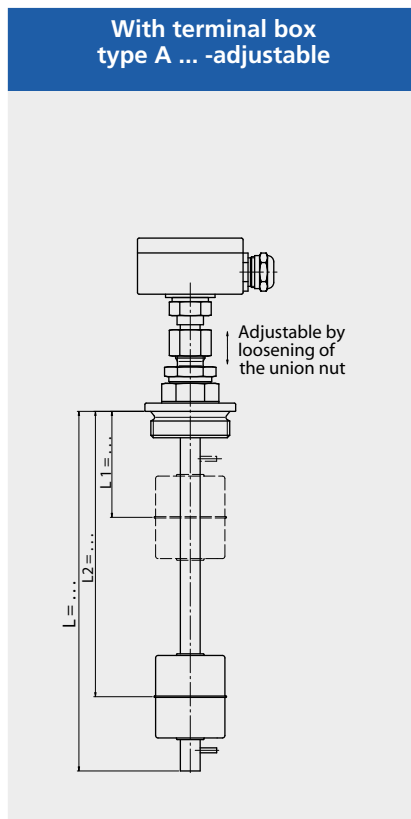
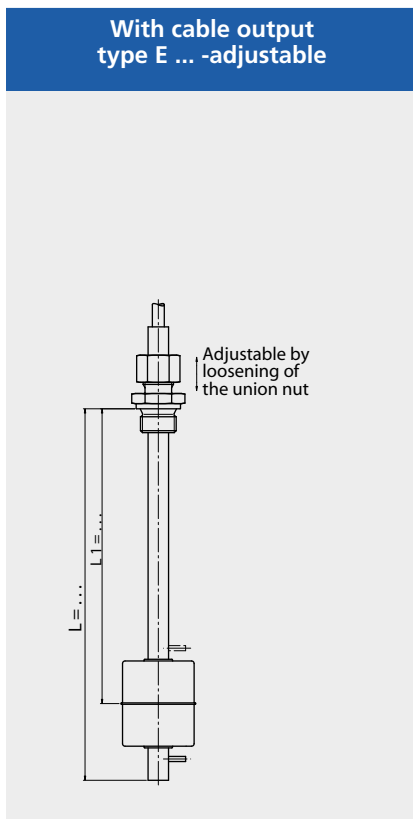

Type combination see type key Magnetic Float Switches

Magnetic Float Switches 1003

Stainless steel and Brass in angled design for side installation

Technical data	Stainless steel	Brass
Guide tube diameter:	8 mm length to 1000 mm 10 mm length to 2000 mm 12 mm length to 5000 mm	12 mm length to 5000 mm
Connection sizes / guide tube:	Thread BSP 1/8" ... Ø 8 mm Thread BSP 3/8" ... Ø12 mm Thread NPT 3/8" ... Ø12 mm Flange DIN DN10 ... Ø10 ...12 mm Flange Ansi 1/2" ... Ø10 ...12 mm	Thread BSP 3/8" ... Ø12 mm Thread NPT 3/8" ... Ø12 mm
Contacts:	U - change over S - normally open O - normally closed	U - change over S - normally open O - normally closed
Temperature contacts:	TO ... °C normally closed TS ... °C normally open	TO ... °C normally closed TS ... °C normally open
Temperature probe:	PT- 100 (optional with control unit) PT-1000 (optional with control unit)	PT- 100 (optional with control unit) PT-1000 (optional with control unit)
Float:	See float table pages 64-70	See float table pages 64-70
Approvals:	See approvals pages 42-43	See approvals pages 42-43
Operating parameters:	Temperature: -30 °C ... +200 °C Pressure: -1 ... 40 bar Specific gravity: ≥400 kg/m ³	Temperature: -10 °C ... +150 °C Pressure: -1 ... 16 bar Specific gravity: ≥400 kg/m ³

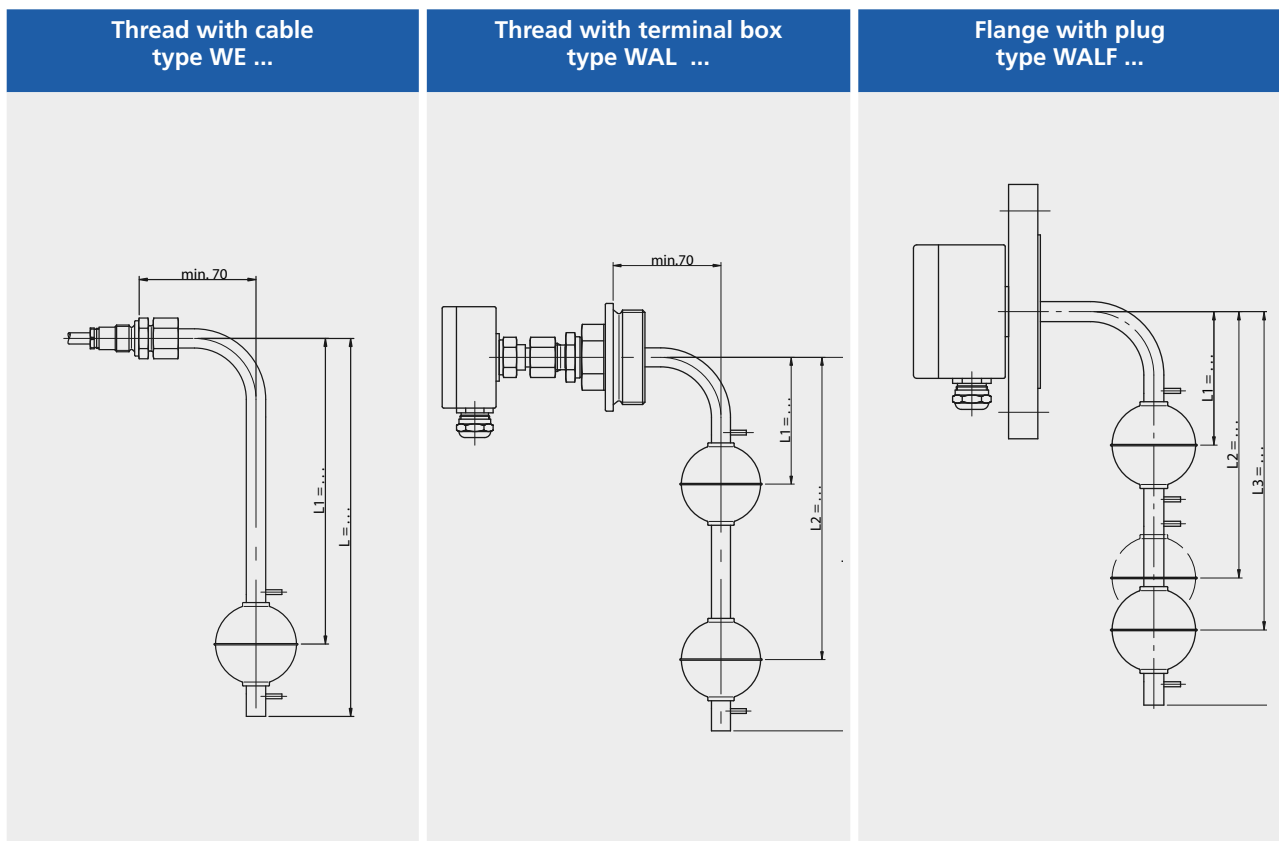

Type combination see type key Magnetic Float Switches

Magnetic Float Switches 1003

E-CTFE and PFA coated stainless steel design

Technical data	E-CTFE coated stainless steel
Guide tube diameter: (without coating)	12 mm length to 5000 mm 14 mm length to 5000 mm 18 mm length to 5000 mm
Connection sizes:	Flange DIN DN50 ... Flange Ansi 2" ...
Contacts:	U - change over S - normally open O - normally closed
Temperature contacts:	TO ... °C normally closed TS ... °C normally open
Temperature probe:	PT- 100 (optional with control unit) PT-1000 (optional with control unit)
Float:	See float table pages 64-67
Approval:	See approvals pages 42-43
Electrical connections:	See connections pages 74-75
Operating parameters:	Temperature: -30 °C ... +150 °C Pressure: -1 ... 25 bar Specific gravity: $\geq 650 \text{ kg/m}^3$

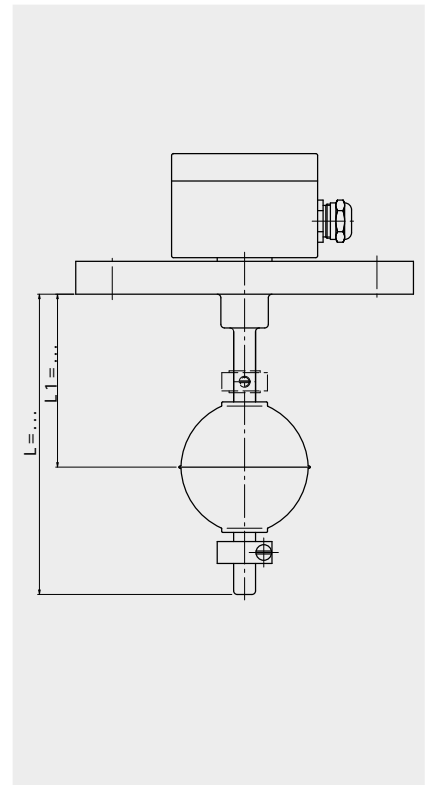

Technical data	PFA coated stainless steel
Guide tube diameter: (without coating)	12 mm length to 5000 mm 14 mm length to 5000 mm 18 mm length to 5000 mm
Connection sizes:	Flange DIN DN50 ... Flange Ansi 2" ...
Contacts:	U - change over S - normally open O - normally closed
Temperature contacts:	TO ... °C normally closed TS ... °C normally open
Temperature probe:	PT- 100 (optional with control unit) PT-1000 (optional with control unit)
Float:	See float table pages 64-67
Approval:	See approvals pages 42-43
Electrical connections:	See connections pages 74-75
Operating parameters:	Temperature: -30 °C ... +200 °C Pressure: -1 ... 25 bar Specific gravity: $\geq 650 \text{ kg/m}^3$

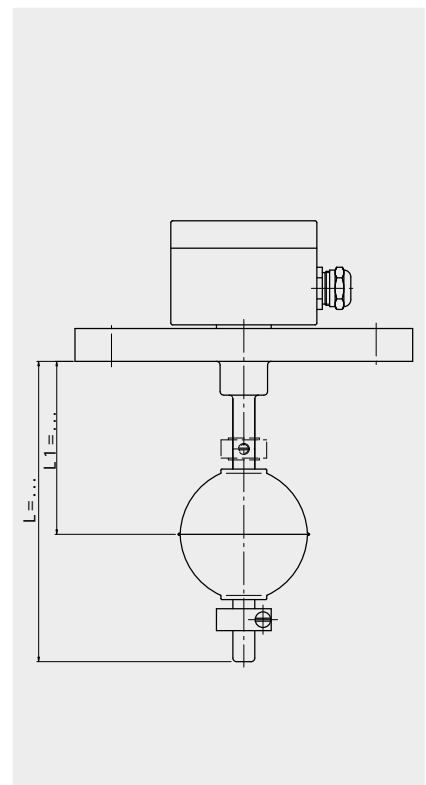

Type combination see type key Magnetic Float Switches

Magnetic Float Switches 1003

Polyamide and Stainless steel in flexible design

Technical data	Polyamide flexible
Guide tube diameter:	12 mm length to 3000 mm
Connection sizes:	Thread BSP 1" ... Thread NPT 1" ... Flange DIN DN25 ... Flange Ansi 1" ...
Stretching weight diameter:	50 mm
Contacts:	U - change over S - normally open O - normally closed
Temperature contacts:	TO ... °C normally closed TS ... °C normally open
Temperature probe:	PT- 100 (optional with control unit) PT-1000 (optional with control unit)
Float:	See float table pages 64-70
Electrical connections:	See connections pages 74-75
Operating parameters:	Temperature: -10 °C ... +80 °C Pressure: -1 ... 1 bar Specific gravity: $\geq 400 \text{ kg/m}^3$ Bending radius: $>500 \text{ mm}$

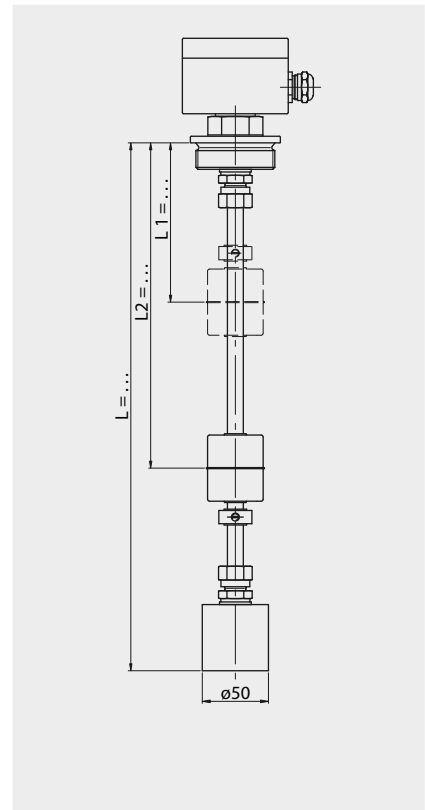

Technical data	Stainless steel flexible
Guide tube diameter:	16 mm length to 20'000 mm
Connection sizes:	Thread BSP 1" ... Thread NPT 1" ... Flange DIN DN25 ... Flange Ansi 1" ...
Stretching weight diameter:	50 mm
Contacts:	U - change over S - normally open O - normally closed
Temperature contacts:	TO ... °C normally closed TS ... °C normally open
Temperature probe:	PT- 100 (optional with control unit) PT-1000 (optional with control unit)
Float:	SV 72/23, SV 80/23 and STI 80/23
Approval:	See approvals pages 42-43
Electrical connections:	See connections pages 74-75
Operating parameters:	Temperature : -30 °C ... +200 °C Pressure: -1 ... 25 bar Specific gravity: $\geq 600 \text{ kg/ m}^3$ Bending radius: $>500 \text{ mm}$

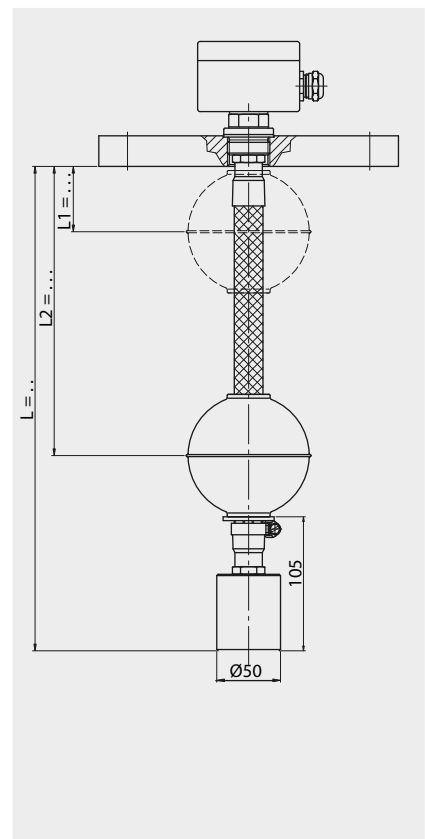

Type combination see type key Magnetic Float Switches

Magnetic Float Switches 1003

PP and PVDF in flexible design

Technical data	PP flexible
Guide tube diameter:	16 mm length to 4000 mm
Connection sizes:	Thread BSP 1" ... Thread NPT 1" ... Flange DIN DN25 ... Flange Ansi 1" ...
Stretching weight diameter:	50 mm
Contacts:	U - change over S - normally open O - normally closed
Temperature contacts:	TO ... °C normally closed TS ... °C normally open
Temperature probe:	PT- 100 (optional with control unit) PT-1000 (optional with control unit)
Float:	See float table pages 68-70
Electrical connections:	See connections pages 74-75
Operating parameters:	Temperature: -5 °C ... +80 °C Pressure: -1 ... 1 bar Specific gravity: $\geq 500 \text{ kg/m}^3$ Bending radius: $>500 \text{ mm}$

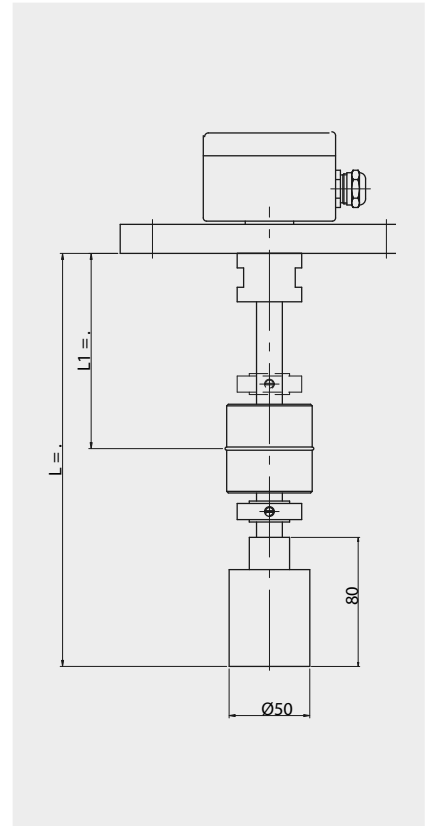

Technical data	PVDF flexible
Guide tube diameter:	16 mm length to 3000 mm
Connection sizes:	Thread BSP 1" ... Thread NPT 1" ... Flange DIN DN25 ... Flange Ansi 1" ...
Stretching weight diameter:	50 mm
Contacts:	U - change over S - normally open O - normally closed
Temperature contacts:	TO ... °C normally closed TS ... °C normally open
Temperature probe:	PT- 100 (optional with control unit) PT-1000 (optional with control unit)
Float:	See float table pages 68-70
Electrical connections:	See connections pages 74-75
Operating parameters:	Temperature : -5 °C ... +100 °C Pressure: -1 ... 1 bar Specific gravity: $\geq 700 \text{ kg/m}^3$ Bending radius: $>500 \text{ mm}$

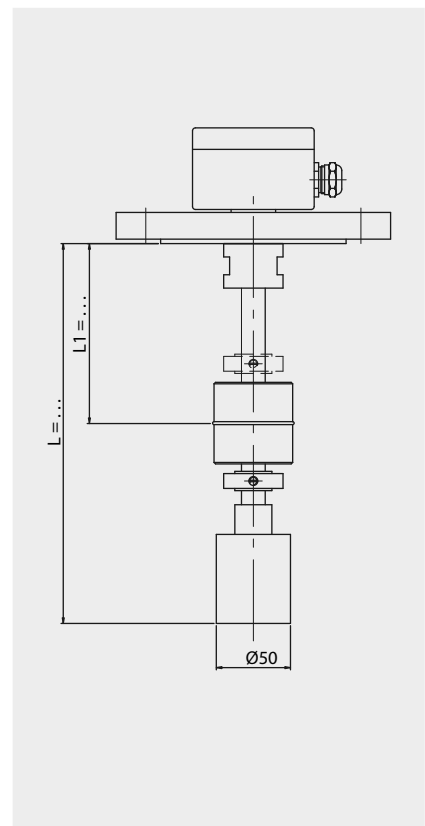

Type combination see type key Magnetic Float Switches

Magnetic Float Switches 1003

Stainless steel and Brass test function design

Technical data	
	... - TEST (Stainless steel)
Guide tube diameter:	14 mm length to 5000 mm
Connection sizes:	Thread BSP 1½" ... Thread NPT 1½" ... Flange DIN DN32 ... Flange Ansi 1½" ...
Contacts:	U - change over S - normally open O - normally closed
Temperature contacts:	TO ... °C normally closed TS ... °C normally open
Temperature probe:	PT- 100 PT-1000
Float:	See float table pages 64-70
Approval:	See approvals pages 42-43
Electrical connections:	See connections pages 74-75
Operating parameters:	Temperature: -10 °C ... +80 °C Pressure: -1 ... 40bar Specific gravity: ≥600 kg/m³ Test function: with pull rod

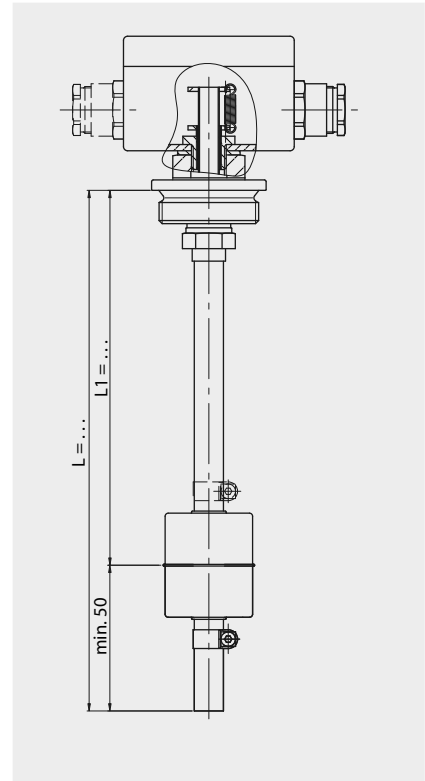

Technical data	
	... - TEST (Brass)
Guide tube diameter:	14 mm length to 4000 mm
Connection sizes:	Thread BSP 1½" ... Thread NPT 1½" ...
Contacts:	U - change over S - normally open O - normally closed
Temperature contacts:	TO ... °C normally closed TS ... °C normally open
Temperature probe:	PT- 100 PT-1000
Float:	See float table pages 64-70
Electrical connections:	See connections pages 74-75
Operating parameters:	Temperature: -10 °C ... +80 °C Pressure: -1 ... 16 bar Specific gravity: ≥600 kg/m³ Test function: with pull rod

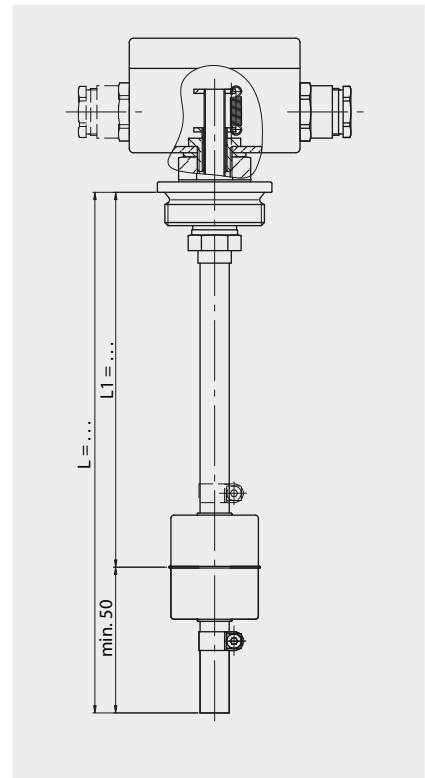

Magnetic Float Switches 1003

Stainless steel with bypass housing

Technical data	ALBV ...
Upright stand pipe:	Ø 60 mm (2")
Chamber distance centre/centre:	55 ... 3000 mm
Connection sizes:	Flange DIN DN15 ... Flange ANSI ½" ... Welding ends ½" ... Thread female or male ¼"
Contacts: (Function on rising level)	U-change over S-normally open O-normally closed
Temperature contacts:	TO ... °C TS ... °C
Temperature probe:	PT- 100 (optional with control unit) PT-1000 (optional with control unit)
Float:	SV52A / SKK44A
Approval:	see approvals page 42-43
Operating parameters:	Temperature: -30 °C ... +200 °C Pressure: -1 ... 40 bar Specific gravity: ≥700 kg/m³

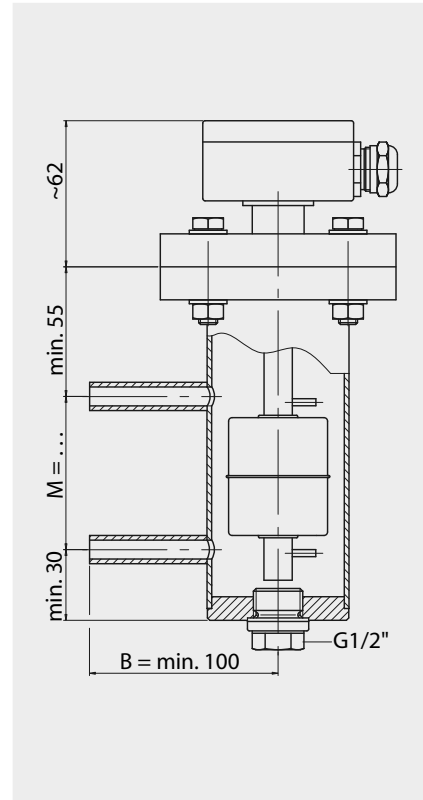

Technical data	ASBV-GN1-VU-L65-SVK27A
Connection sizes:	Internal screw thread: BSP1"
Contacts:	U-change over
Temperature contacts:	TO ... °C TS ... °C
Temperature probe:	PT- 100 (optional with control unit) Pt-1000 (optional with control unit)
Float:	SV27A
Approval:	see approvals page 42-43
Operating parameters:	Temperature: -30 °C ... +200 °C Pressure: -1 ... 40 bar Specific gravity: ≥700 kg/m³

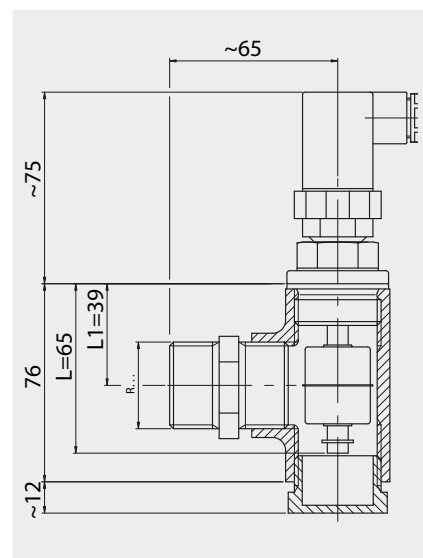

Type combination see type key Magnetic Float Switches

Magnetic Float Switches 1003

Gunmetal and Aluminium with bypass housing

Technical data	ALBR ...
Chamber distance centre/centre:	M = 55 mm
Connection sizes:	Thread female or male 1/4"
Contacts:	U - change over S - normally open O - normally closed
Temperature contacts:	TO ... °C normally closed TS ... °C normally open
Temperature probe:	PT- 100 (optional with control unit) PT-1000 (optional with control unit)
Float:	SV52A / SVK44A
Approval:	See approvals pages 42-43
Operating parameters:	Temperature: -30 °C ... +200 °C Pressure: -1 ... 40 bar Specific gravity: $\geq 700 \text{ kg/m}^3$

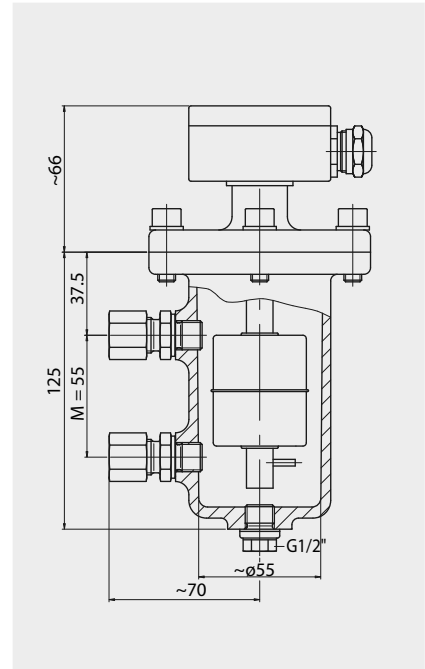

Technical data	ALBA ...
Distance centre/centre:	Distance centre/centre: 55 mm
Connection sizes:	Flange DIN DN15 ... DN50 Flange Ansi 1/2" ... 2" Welding ends 1/2" ... 2" Locking ring 1/4" Thread female or male 1/4" ... 1"
Contacts:	U - change over S - normally open O - normally closed
Temperature contacts:	TO ... °C normally closed TS ... °C normally open
Temperature probe:	PT- 100 (with control unit) PT-1000 (with control unit)
Float:	SV52 / SVK
Approval:	See approvals pages 42-43
Electrical connections:	See connections pages 74-75
Operating parameters:	Temperature: -30 °C ... +150 °C Pressure: -1 ... 6 bar Specific gravity: $\geq 700 \text{ kg/m}^3$

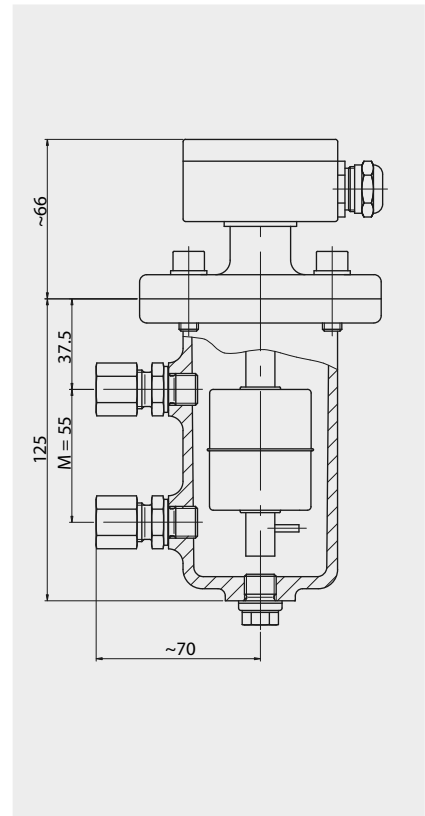

Type combination see type key Magnetic Float Switches

Magnetic Float Switches 1003

SNU-Safety switch

Technical data	
Guide tube diameter:	12 mm length to 2000 mm
Connection sizes:	Thread BSP 2" Thread NPT 2" Flange DIN DN50 ... DN250 Flange Ansi 2" ... 10"
Contacts:	U - change over S - normally open O - normally closed
Temperature contacts:	-
Temperature probe:	-
Float:	ZVS50/...
Electrical connections:	See connections pages 74-75
Operating parameters:	Temperature: -10 °C ... +150 °C Pressure: -1 ... 16 bar Specific gravity: $\geq 700 \text{ kg/m}^3$

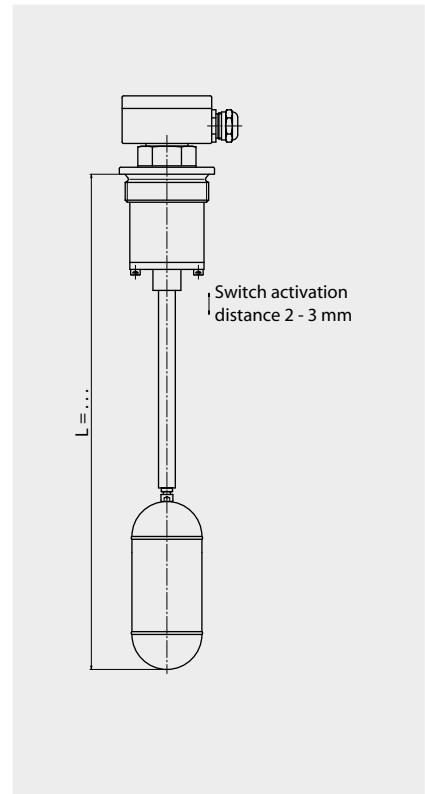

Technical data	
Chain or Rope mounting:	Chain suspension to 3000 mm Rope suspension to 4000 mm
Connection sizes:	Thread BSP 2" Thread NPT 2" Flange DIN DN50 ... DN250 Flange Ansi 2" ... 10"
Contacts:	U - change over S - normally open O - normally closed
Temperature contacts:	-
Temperature probe:	-
Float:	SV82
Electrical connections:	See connections pages 74-75
Operating parameters:	Temperature: -10 °C ... +150 °C Pressure: -1 ... 16 bar Specific gravity: $\geq 700 \text{ kg/m}^3$

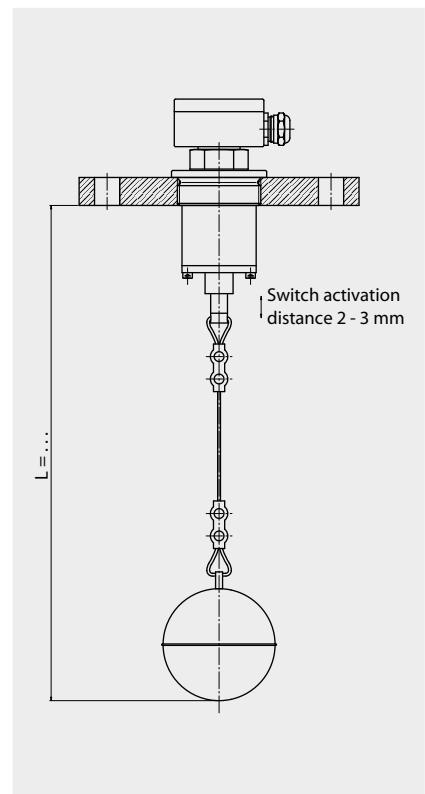

Type combination see type key Magnetic Float Switches

Magnetic Float Switches 1003

For bulk material and viscous media

Technical data	
Guide tube diameter:	12 mm length to 3000 mm
Connection sizes:	Thread BSP 1½" ... 2" Thread NPT 1½" ... 2" Flange DIN DN50 ... DN250 Flange Ansi 2" ... 10"
Contacts:	U - change over S - normally open O - normally closed
Paddle design:	40 x 100 mm
Electrical connections:	See connections pages 74-75
Operating parameters:	Temperature: -10 °C ... +200 °C Pressure: -1 ... 40 bar With adjusting unit: 0 ... 3 bar

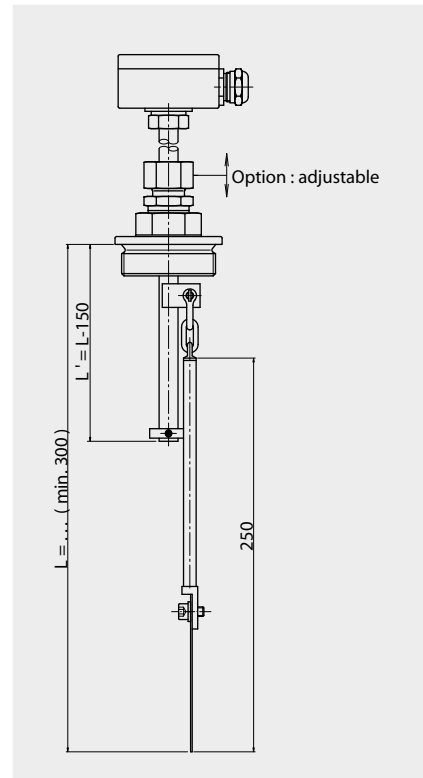

Technical data	
Guide tube diameter:	12 mm length to 3000 mm
Connection sizes:	Thread BSP 1½" ... 2" Thread NPT 1½" ... 2" Flange DIN DN50 ... DN250 Flange Ansi 2" ... 10"
Contacts:	U - change over S - normally open O - normally closed
Float:	ZVSS42/100
Electrical connections:	See connections pages 74-75
Operating parameters:	Temperature: -10 °C ... +150 °C Pressure: -1 ... 16 bar With adjusting unit: 0 ... 3 bar

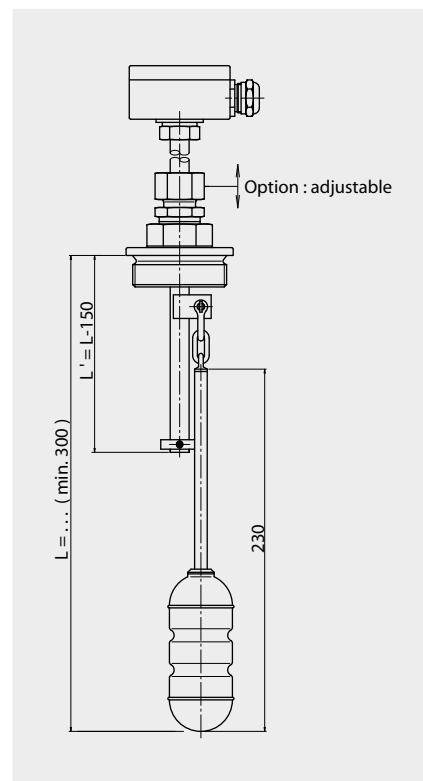

Type combination see type key Magnetic Float Switches

Magnetic Float Switches 1003

Spherical float with axial-magnetic system

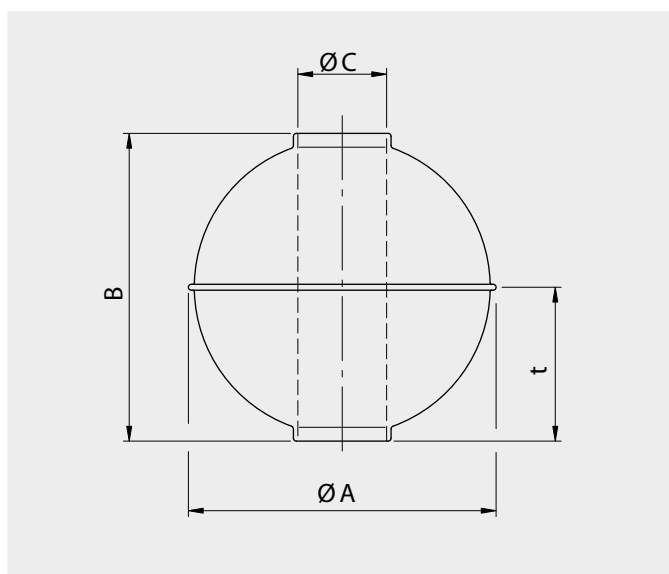

Type	Material	Ø A [mm]	B [mm]	Ø C [mm]	Min. gravity [kg/m ³]	Max. oper. pressure [bar]	Max. oper. temp. [°C]	Weight [g]	Immersion depth t by gravity 1 [mm]
SV 29A	St. steel	29	28	9.4	900	35	200	7	20
SV 44A	St. steel	42	42	9.4	650	15	200	19	23
SV 52A	St. steel	52	52	15	700	40	200	37	30
SV 62A	St. steel	62	63	15	600	25	200	55	31
SV 72V	St. steel	72	72	15	460	25	200	73	32
SV 72/24V	St. steel	72	70	24	620	25	200	86	39
SV 82A	St. steel	82	82	15	400	25	200	88	32
SV 80/23A	St. steel	80	75	23	620	25	200	114	42
SV 80/3A	St. steel	80	72	23	750	45	200	158	49
SV 98A	St. steel	98	96	23	560	25	200	222	50
STS 44V	Titanium	44	44	12	780	100	300	25	28
STS 52V	Titanium	52	52	15	750	150	300	42	33
STI 29A	Titanium	29	28	9.4	700	15	150	6	17
STI 52A	Titanium	52	52	14	650	22	150	36	29
STI 82A	Titanium	82	80	15	500	16	150	75	29
STI 80/24A	Titanium	80	76	24	600	16	150	103	40
SH 52A	Alloy C	52	52	15	1250	55	200	68	-
SH 62A	Alloy C	62	60	15	880	30	200	86	44
SH 72/23V	Alloy C	72	72	23	820	25	200	116	48
SH 82V	Alloy C	82	80	15	500	16	200	95	34
SH 82/23V	Alloy C	82	80	23	700	18	200	150	48
SH 98V	Alloy C	98	96	23	550	16	200	208	47
SEECV80/23V	E-CTFE coated	82	78	21	650	25	150	133	44
SEECV72/23V	E-CTFE coated	74	72	21	650	25	150	101	40

Specifications subject to change

Magnetic Float Switches 1003

Immersion depths-diagram

Spherical float with axial-magnetic system

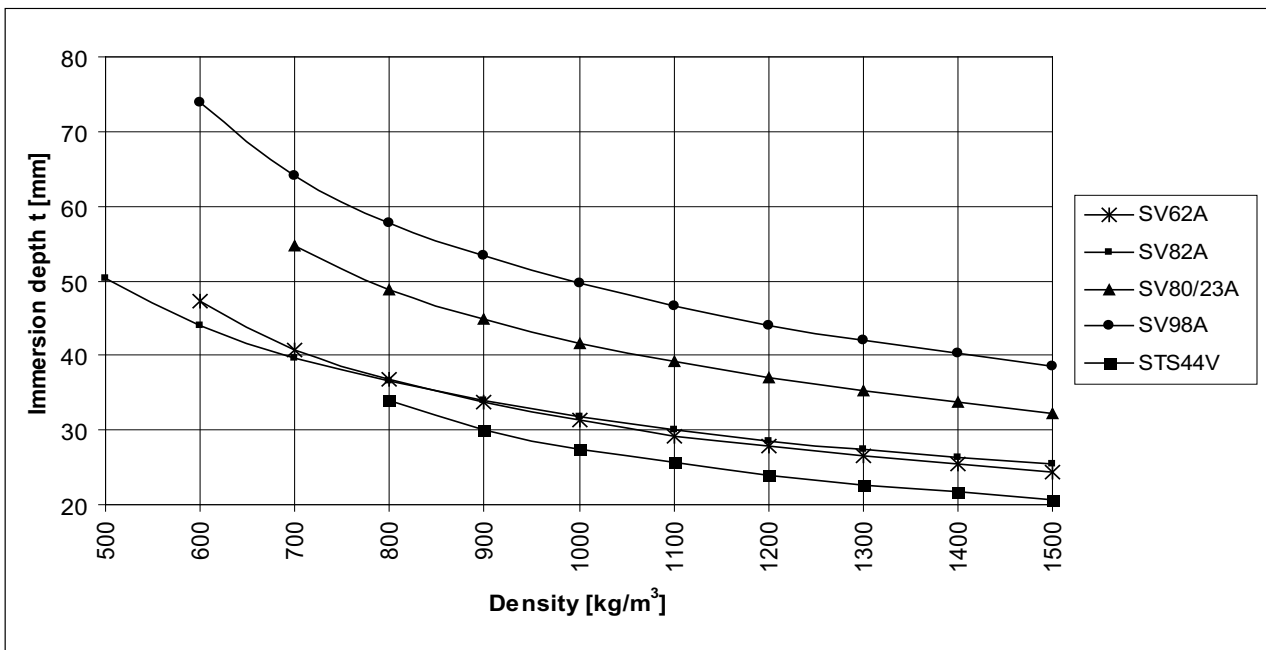
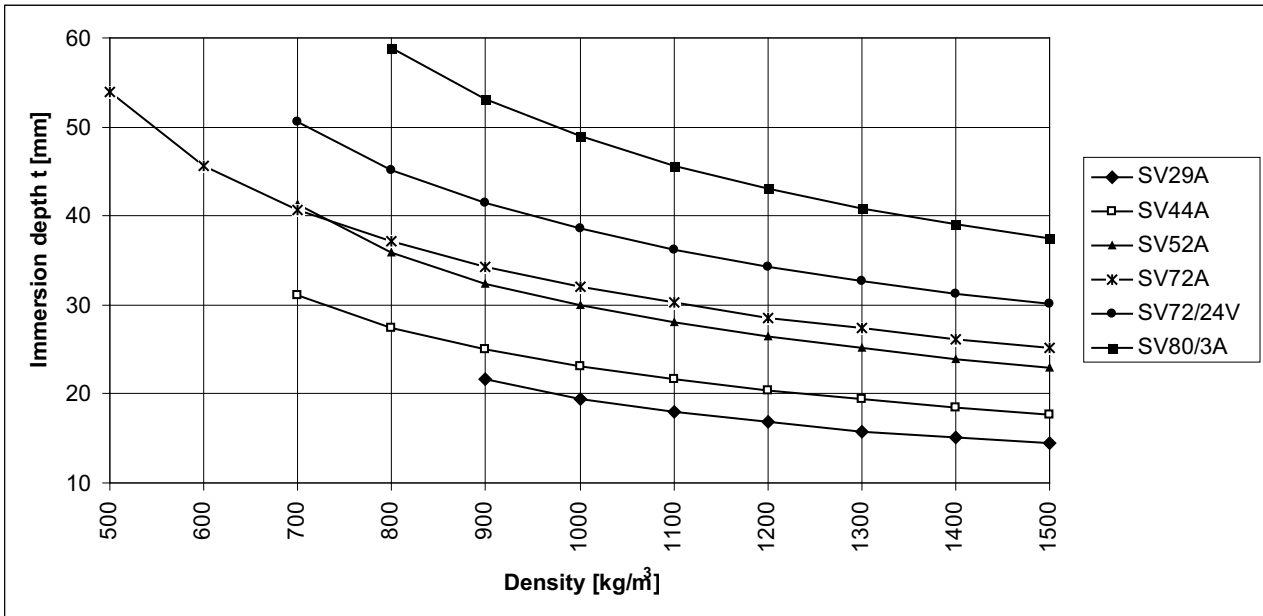

Magnetic Float Switches 1003

Immersion depths-diagram

Spherical float with axial-magnetic system

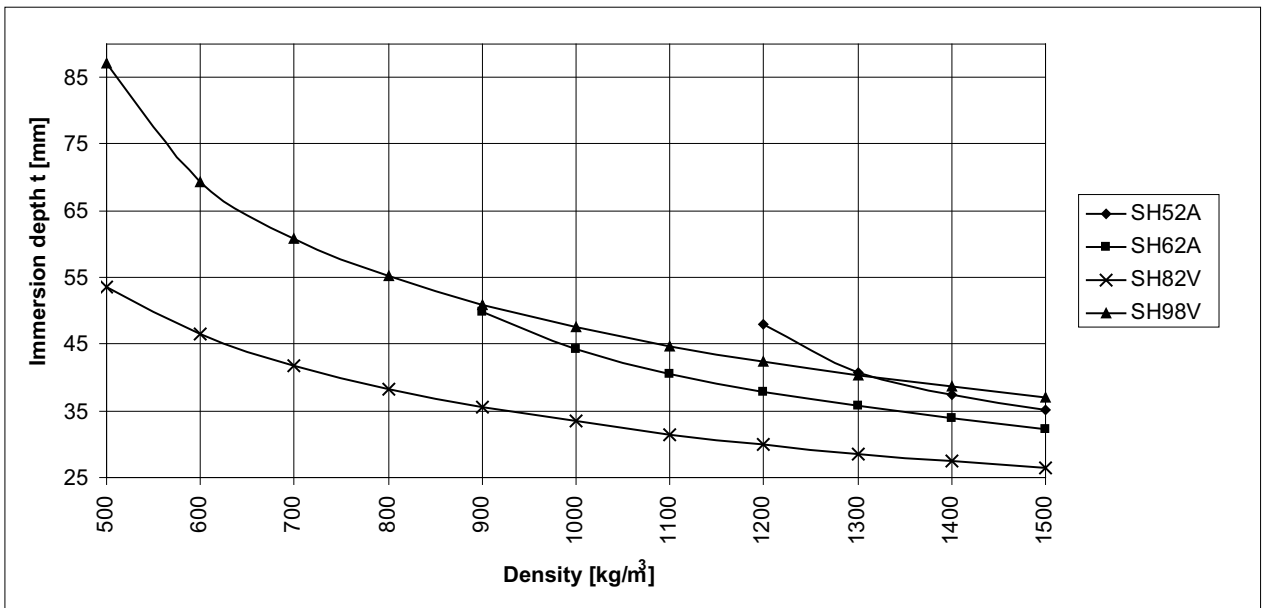
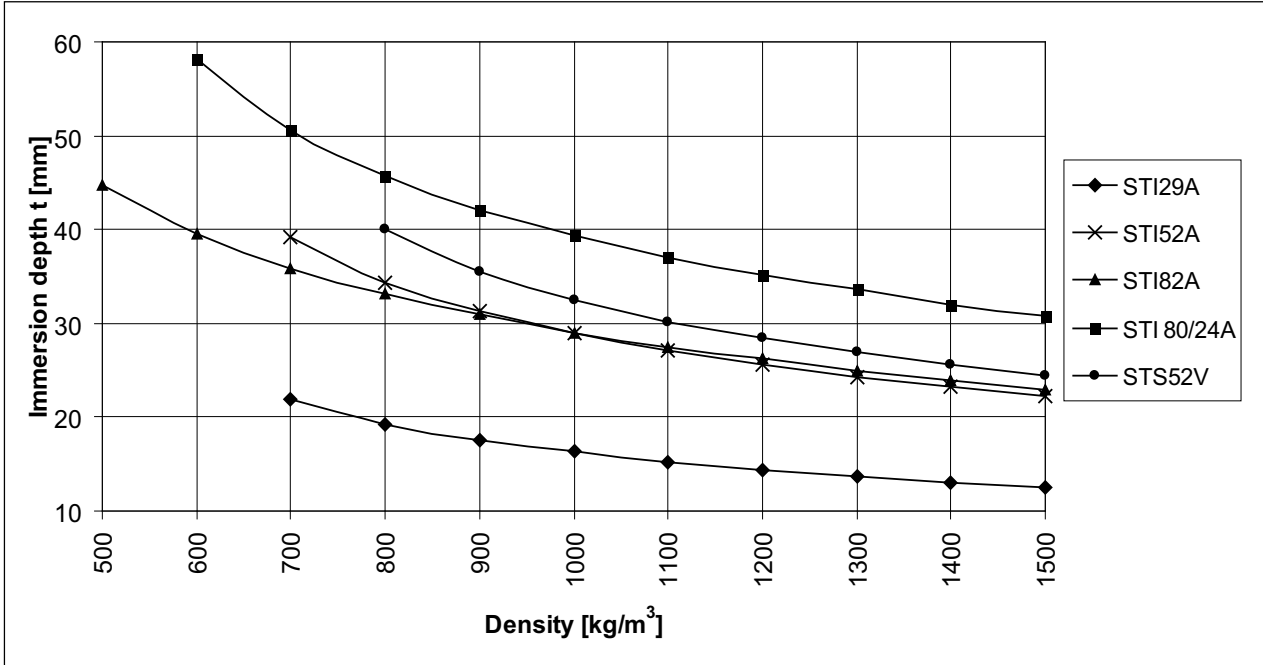

Magnetic Float Switches 1003

Immersion depths-diagram

Spherical float with axial-magnetic system

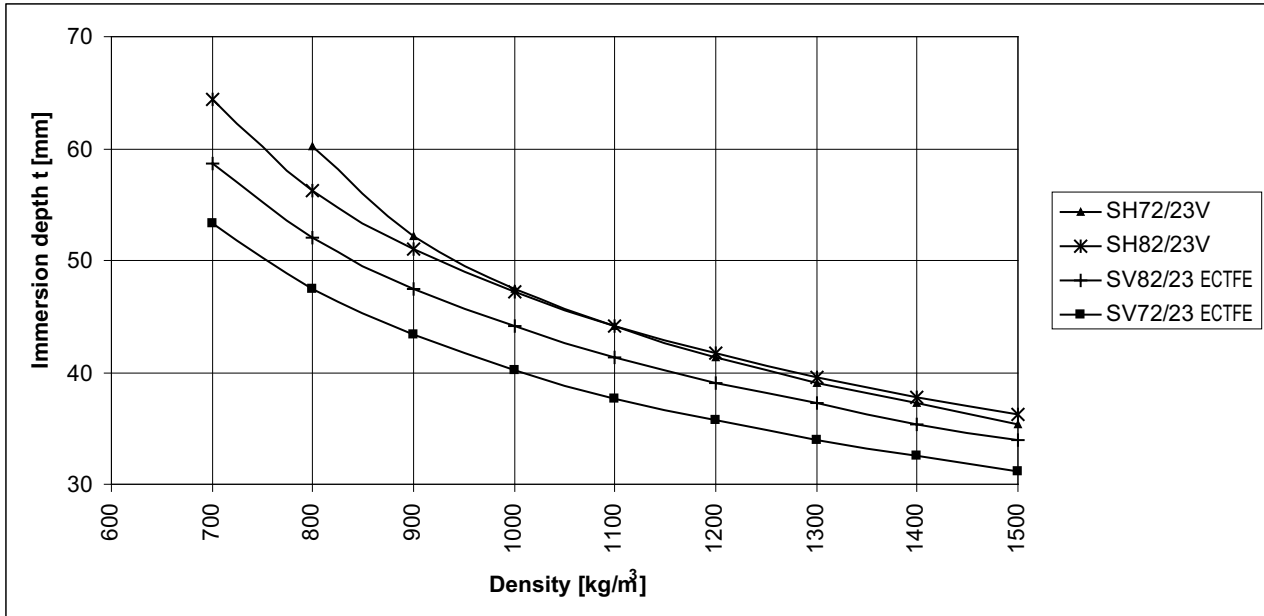

Magnetic Float Switches 1003

Cylindrical float with axial-magnetic system

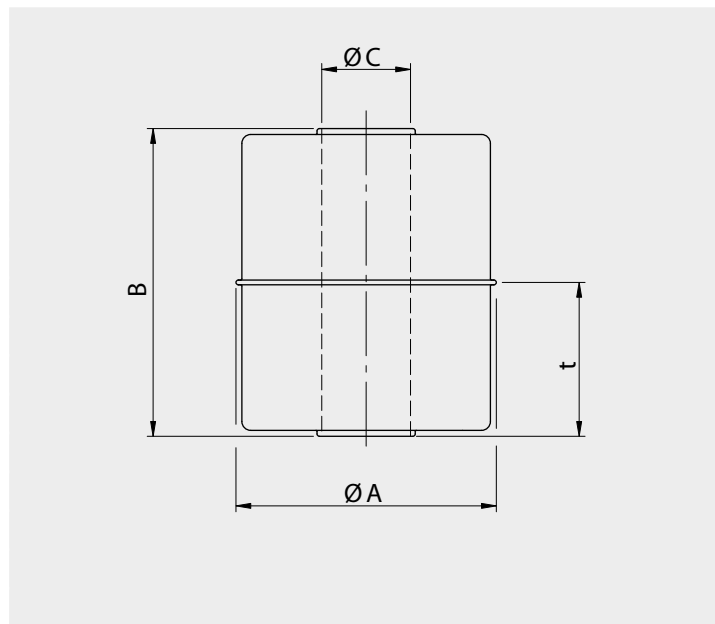

Type	Material	$\varnothing A$ [mm]	B [mm]	$\varnothing C$ [mm]	Min. gravity [kg/m ³]	Max. oper. pressure [bar]	Max. oper. temp. [°C]	Weight [g]	Immersion depth t [mm]
SVK27A	St. steel	27	31	10	800	6	200	7.5	18
SVK44A	St. steel	44	52	15	800	25	200	39	32
STK44A	Titanium	44	52	14	750	15	150	37	30
SHK44A	Alloy	44	52	15	1000	45	200	52	43
SB23A	NBR	23	25	8.4	800	6	80	5	14
SB25A	NBR	25	14	9	800	6	80	3.5	8
SB30A	NBR	30	45	13	700	6	80	14	24
SB40A	NBR	40	30	15	700	6	80	17	16
SP44A	PVC	44	44	14	800	1	60	32	26
SP55A	PVC	55	55	22	750	1	60	64	34
SP80A	PVC	80	80	25	600	1	60	164	38
SPP26A	PP	27	30	8	800	1	80	9	19
SPP44A	PP	44	44	13	700	1	80	25	20
SPP55A	PP	55	55	21	600	1	80	50	26
SPP80A	PP	80	80	24	500	1	80	126	29
SPF44A	PVDF	44	57	13	850	1	100	46	37
SPF55A	PVDF	55	70	21	800	1	100	90	47
SPF80A	PVDF	80	80	24	700	1	100	192	45

Specifications subject to change

Magnetic Float Switches 1003

Immersion depths-diagram

Cylindrical float with axial-magnetic system

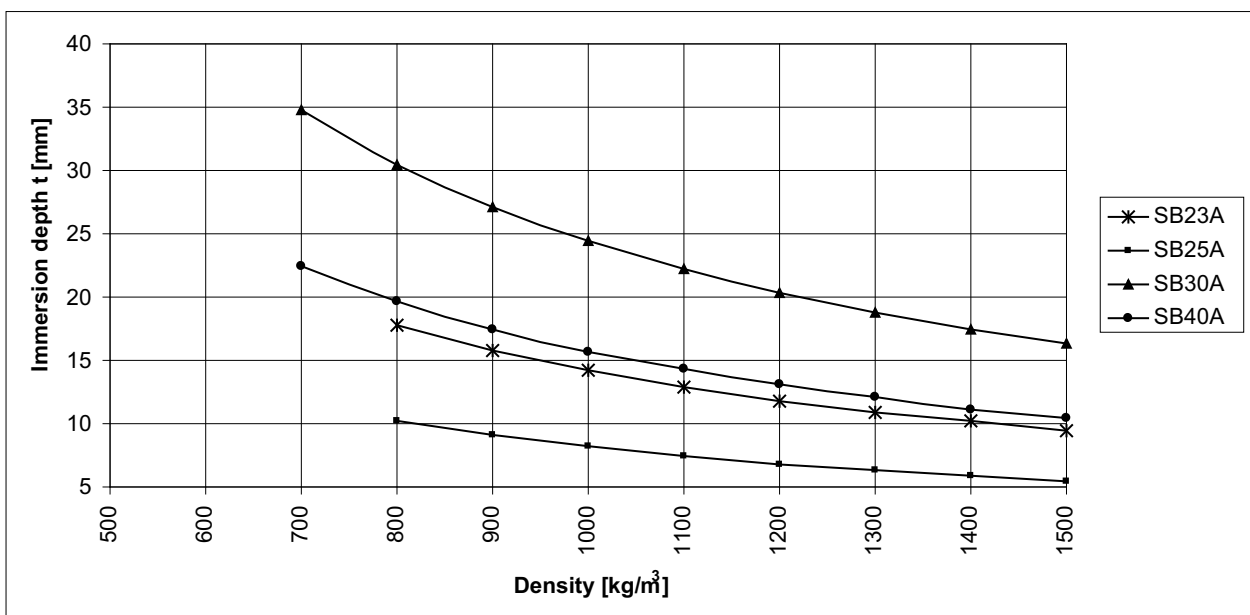
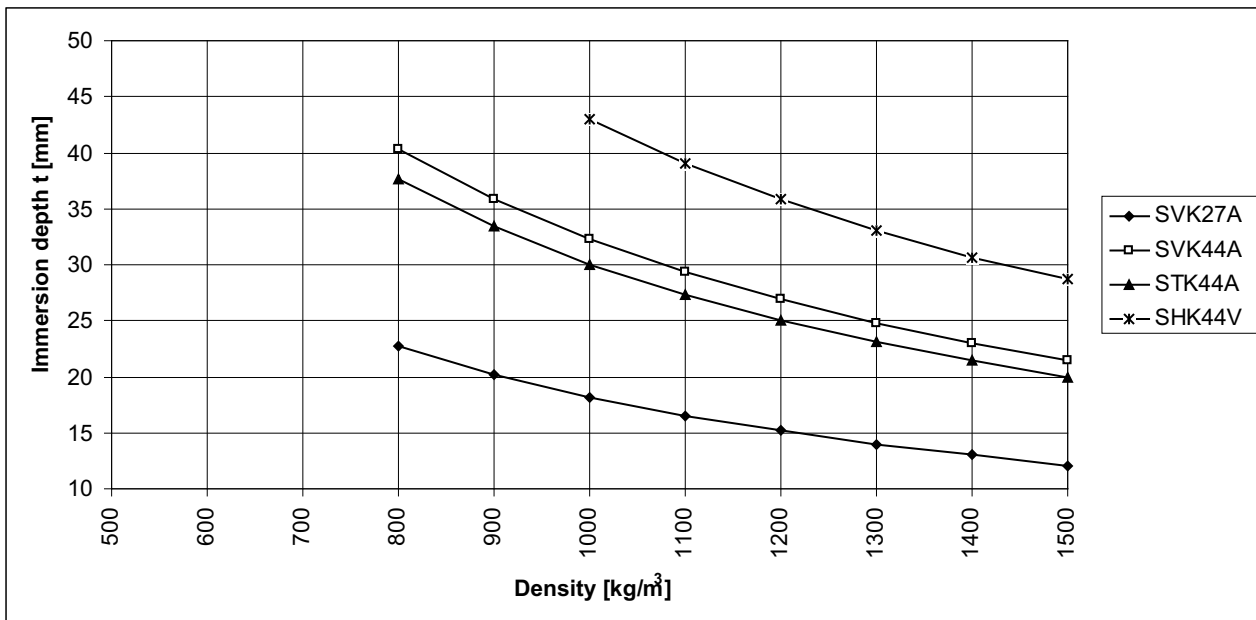

Magnetic Float Switches 1003

Immersion depths-diagram

Cylindrical float with axial-magnetic system

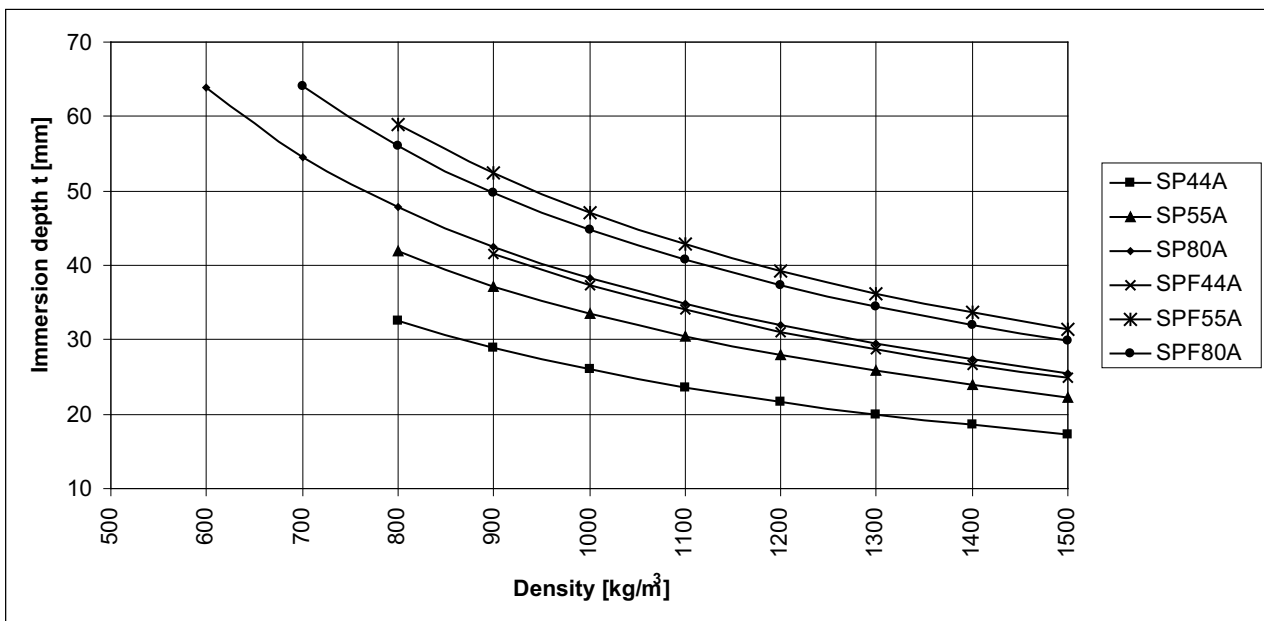
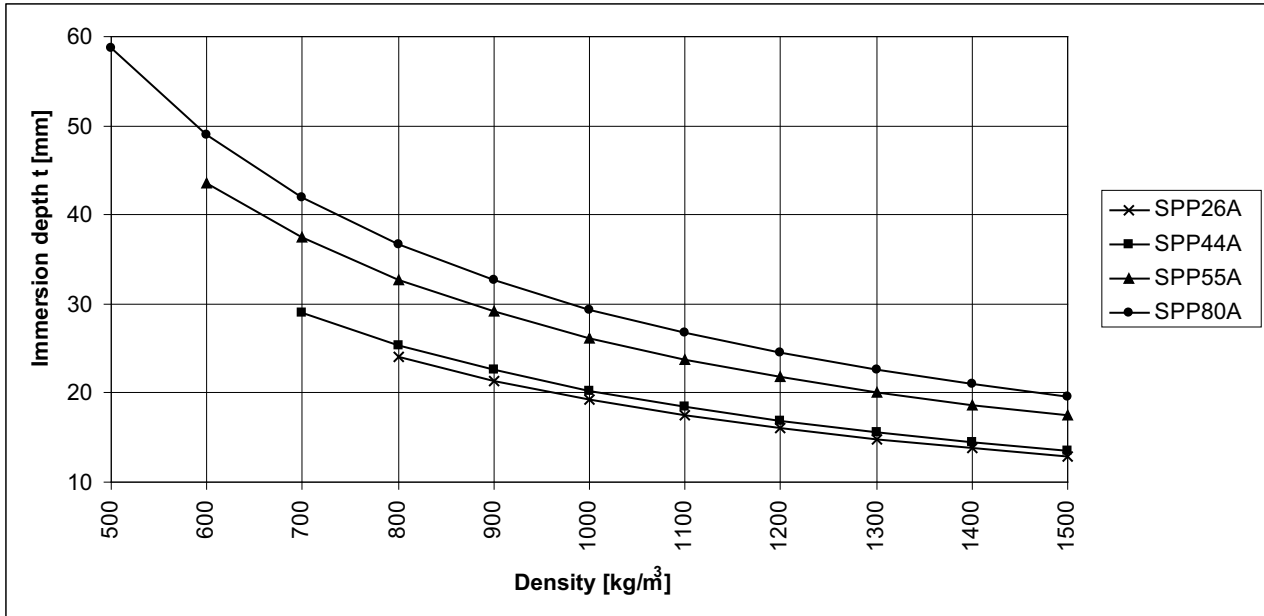

Magnetic Float Switches 1003

Type key

Code 1	Key 1	Electrical connection	ATEX
	AL ... -	Aluminium terminal box	Ⓔ
	AV ... -	Stainless steel terminal box	Ⓔ
	ALDC ... -	Aluminium terminal box EExd explosion proof	Ⓔ
	ALD ... -	Aluminium terminal box EExd explosion proof	Ⓔ
	AVD ... -	Stainless steel terminal box EExd explosion proof	Ⓔ
	AP ... -	Terminal box Polyester	Ⓔ
	AB ... -	Terminal box ABS	
	AS ... -	Connection plug	Ⓔ
	AF ... -	Connection plug with PA-flange	
	E ... -	Connection cable	Ⓔ
	ALB ... -	Aluminium terminal box (for bypass housing)	Ⓔ
	ASB ... -	Connection plug (for bypass housing)	Ⓔ
	EB ... -	Connection cable (for bypass housing)	Ⓔ
	U ... -	Mounting from bottom	Ⓔ
	W ... -	Bent designs	Ⓔ
	... -	Various	
	Key 2	Materials of process connections	ATEX
	.. V ... -	Stainless steel	Ⓔ
	.. Ti ... -	Titanium	Ⓔ
	.. H ... -	Alloy	Ⓔ
	.. S ... -	Steel	
	.. R ... -	Gunmetal	
	.. M ... -	Brass	
	.. EEC ... -	Stainless steel E-CTFE coated	Ⓔ
	.. PFA ... -	Stainless steel PFA coated	Ⓔ
	.. A ... -	Aluminium	
	.. P ... -	Polyvinylchloride PVC	
	.. PP ... -	Polypropylene PP	
	.. PF ... -	Polyvinylidenfluoride PVDF	
	... -	Various	
	Key 3	Design process connection	ATEX
	... E ... -	Thread to the top DIN G 1/8" ... / ≥ M10	Ⓔ
	... ENPT ... -	Thread to the top NPT 1/8" ...	Ⓔ
	... R ... -	Thread to the bottom DIN G 3/8" ... / ≥ M10	Ⓔ
	... NPT ... -	Thread to the bottom NPT 3/8" ...	Ⓔ
	... BKNW ... -	Screwed connection acc.to DIN 11851, NW25 ...	Ⓔ
	... TC ... -	Tri-clamp flange DN 25 ... / 1/2" ...	Ⓔ
	... F -	Flange acc. to different standards	Ⓔ
	... VE -	Various	

Type combination

Code	1	2	3	4	5	6	7	8
Key	1/2/3	1/1/1	1/2/3	1	1	1	1	1
Example	EVF -	50/16/C -	VU/TS -	1TF -	L450 -	SVK44 -	3PVC -	Ex

Magnetic Float Switches 1003

Type key

Code 2	Key 1	Flange dimensions and designs	ATEX	
	.. / .. / .. -	Standard	1. nom.width 2. nom.pressure 3. form	Ⓔ
		DIN	DN 15 ... 500 PN 6 ... 400 C, F, N, B ...	Ⓔ
		ANSI	1/2" ... 20" 150 ... 2500 lbs SF, RTJ, FF...	Ⓔ
		JIS B 2010	1/2" ... 20" 5K ... 63K SF, RTJ, FF ...	Ⓔ
		BSI BS 4504	DN 15 ... 500 PN 6 ... 400 6/x ... 400/x	Ⓔ
		BSI BS 10	1/2" ... 20" 150 ... 2500 lbs A ... T	Ⓔ
		S	Special flange acc. to drawing	
Code 3	Key 1	Guide tube material	ATEX	
	V .. -	Stainless steel (also flexible design)	Ⓔ	
	Ti .. -	Titanium	Ⓔ	
	H .. -	Alloy	Ⓔ	
	M .. -	Brass		
	EEC .. -	Stainless steel E-CTFE coated	Ⓔ	
	PFA .. -	Stainless steel PFA coated	Ⓔ	
	P .. -	Polyvinylchloride PVC		
	PP .. -	Polypropylene PP (also flexible design)		
	PF .. -	Polyvinylidenfluoride PVDF (also flexible design)		
	PA .. -	Polyamide PA (flexible design)		
	.. -	Various		
	Key 2	Contact functions	ATEX	
	.. U	Change over	Ⓔ	
	.. U/R	Change over with 22 Ohm protective resistor	Ⓔ	
	.. U/N	Change over with Namur circuit acc. to EN 60947	Ⓔ	
	.. S	Normally opened - closing on rising level	Ⓔ	
	.. S/R	Normally opened - closing on rising level with 22 Ohm protective resistor	Ⓔ	
	.. O	Normally closed - opening on rising level	Ⓔ	
	.. O/R	Normally closed - opening on rising level with 22 Ohm protective resistor	Ⓔ	
		Option: (H) hysteresis to approx. 10 mm / e.g. .. U(H)/..		
	Key 3	Temperature contact	ATEX	
	... / TO -	With temperature contact normally closed - opening on rising level	Ⓔ	
	... / TS -	With temperature contact normally open - closing on rising level	Ⓔ	
Code 4	Key 1	Temperature probe / temperature control unit	ATEX	
	.. TF -	Quantity temperature probe without control unit	Ⓔ	
	.. TF / TP -	Quantity temperature probe with control unit TP5333 A/B	Ⓔ (B)	
	.. TF / TD -	Quantity temperature probe with control unit TP5335 A/B	Ⓔ (B)	
	.. TF / TP50 -	Quantity temperature probe with control unit TP5350 A/B	Ⓔ (B)	
		(control units only possible with terminal boxes)		

Type combination

Code	1	2	3	4	5	6	7	8
Key	1/2/3	1/1/1	1/2/3	1	1	1	1	1
Example	EVF -	50/16/C -	VU/TS -	1TF -	L450 -	SVK44 -	3PVC -	Ex

Magnetic Float Switches 1003

Type key

Code 5	Key 1	Length of guide tube	ATEX
	L .. -	Length of guide tube	
	M .. -	Distance centre to centre	
Code 6	Key 1	Float designs	ATEX
	SV .. -	Stainless steel	
	STi .. -	Titanium	
	SH .. -	Alloy	
	SEEC .. -	Stainless steel E-CTFE coated	
	SPFA .. -	Stainless steel PFA coated	
	SP .. -	Polyvinylchloride PVC	
	SPP .. -	Polypropylene PP	
	SPF .. -	Polyvinylidenfluoride PVDF	
	SB .. -	Buna	
.. -	Various		
Code 7	Key 1	Cable / length of cable in m	ATEX
	.. PVC -	.. Polyvinylchloride PVC (PVC-grey)	
	.. PVC-blau -	.. Polyvinylchloride PVC (PVC-blue)	
	.. Sil -	.. Silicone	
	.. PUR -	.. Pur (partly oil resisting)	
	.. FEP -	.. Teflon	
	.. Lit -	.. Insulated stranded wire	
	.. NiLit -	.. Insulated nickel stranded wire	
	.. Radox -	.. Radox	
 Various	
	... / CY	Shielded cable	
... / ÖL	Oil resisting cable		
Code 8	Key 1	Approvals and options	ATEX
	Ex	Intrinsically safe design acc.to EExia / EExib	
	EExd	Explosion proof design acc.to EExd	
	Ex/D	Intrinsically safe design acc.to EExia with dust Ex	
	EExd/D	Explosion proof design acc.to EExd with dust Ex	
	WHG	Wasserhaushaltsgesetz (Germany)	
	GL	Germanischer Lloyd	
	BV	Bureau Veritas	
	RINA	Registro Italiano Navale	
	3A	3A Sanitary Standard (Food design)	
	TEST	With test function	
	FLEXIBLE	Flexible guide tube design	
	ADJUSTABLE	Adjustable design	

Type combination

Code	1	2	3	4	5	6	7	8
Key	1/2/3	1/1/1	1/2/3	1	1	1	1	1
Example	EVF -	50/16/C -	VU/TS -	1TF -	L450 -	SVK44 -	3PVC -	Ex

Magnetic Float Switches 1003

Electrical connections

Terminal box

Type AL (101)

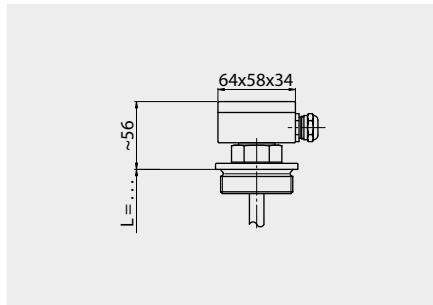

Ambient temperature: max. +150 °C
 Material: Aluminium
 Cable gland: Brass nickel-plated
 Cable entry: M20x1.5 mm
 Protection rating: IP 65

Type AL (105)

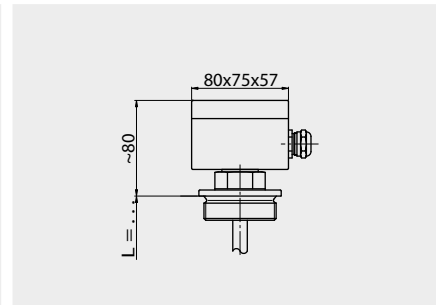

Ambient temperature: max. +150 °C
 Material: Aluminium
 Cable gland: Brass nickel-plated
 Cable entry: M20x1.5 mm
 Protection rating: IP 65

Terminal box

Type ALDC (EExd)

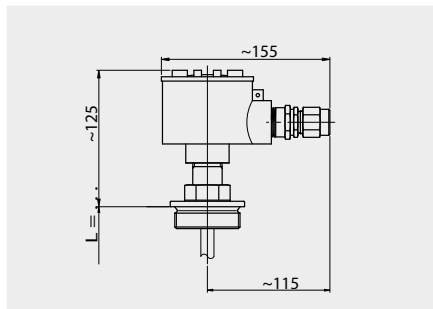

Ambient temperature: max. +85 °C
 Material: Aluminium
 Cable gland: Brass nickel-plated
 Cable entry: M20x1.5 mm
 Protection rating: IP 65

Type ALD (EExd)

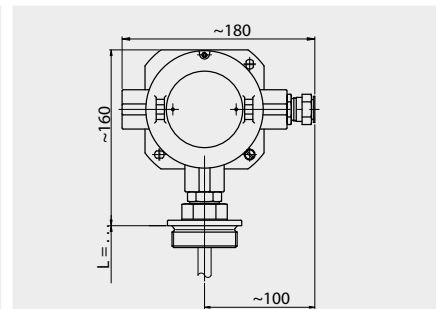

Ambient temperature: max. +55 °C
 Material: Aluminium
 Cable gland: Brass nickel-plated
 Cable entry: M20x1.5 mm
 Protection rating: IP 66

Terminal box

Type AV/AVD (EExd)

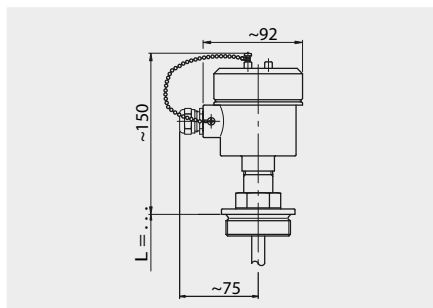

Ambient temperature: max. +40 °C (AVD)
 max. +130 °C (AV)
 Material: Stainless steel
 Cable gland: Brass nickel-plated
 Cable entry: M20x1.5 mm
 Protection rating: IP 65
 Option: Cable gland
 M20x1.5 mm in stainless steel

Type AP

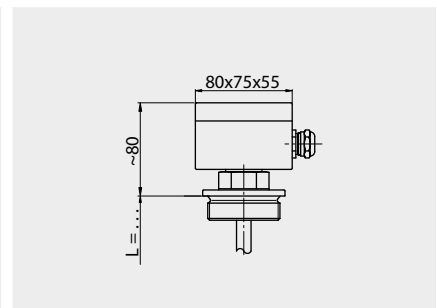

Ambient temperature: max. +100 °C
 Material: Polyester
 Cable gland: Polyamide
 Cable entry: M20x1.5 mm
 Protection rating: IP 65

Magnetic Float Switches 1003

Electrical connections

Terminal box / Cable

Type AB

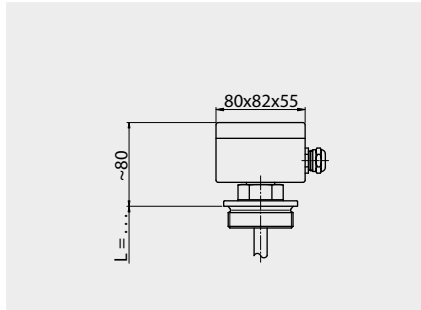

Ambient temperature: max. +80 °C
 Material: ABS
 Cable gland: PVC
 Cable entry: M20x1.5 mm
 Protection rating: IP 65

Type E

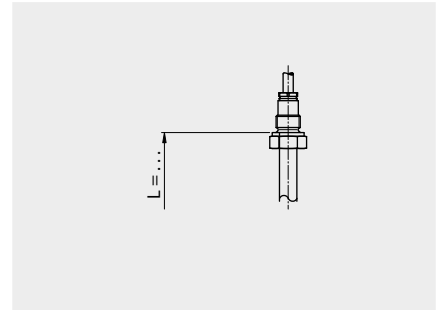

Ambient temperature: max. +180 °C
 Material: Various
 Cable gland: Brass nickel-plated
 Cable entry: Various
 Protection rating: IP 55-68

Connection plug

Type AS

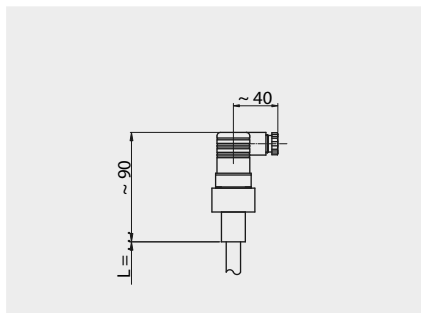

Ambient temperature: max. +80 °C
 Material: PVC
 Cable gland: PA
 Cable entry: -
 Protection rating: IP 65

Type AF

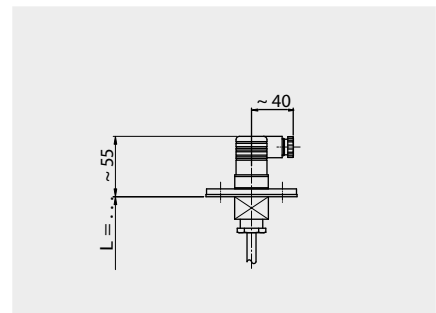

Ambient temperature: max. +80 °C
 Material: PA / PVC
 Cable gland: PA
 Cable entry: -
 Protection rating: IP 65

Connection plug

Type AS

(HTS)

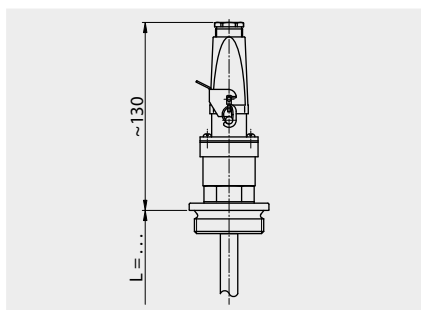

Ambient temperature: max. +80 °C
 Material: Thermoplast / Aluminium
 Cable gland: PA / Alu
 Cable entry: -
 Protection rating: IP 65

Type AS

(W/HTS)

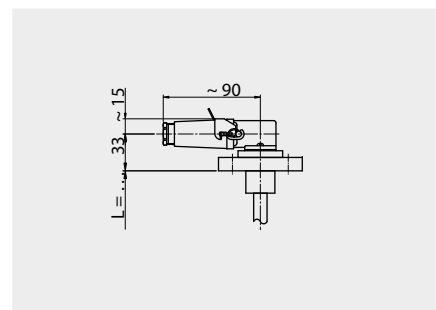

Ambient temperature: max. +80 °C
 Material: Thermoplast / Aluminium
 Cable gland: PA / Alu
 Cable entry: -
 Protection rating: IP 65

Magnetic Float Switches 1003

Design process connections

Thread G ..."

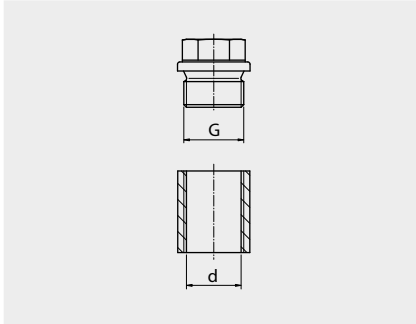

Size	Diameter G [mm]	Core \varnothing d [mm]	Bore [mm]
1/8"	9.7	8.5	8.0
1/4"	13.2	11.4	11.0
3/8"	16.7	14.9	14.5
1/2"	21.0	18.9	18.0
3/4"	26.5	24.1	23.5
1"	33.3	30.2	29.5
1 1/2"	47.8	44.9	44.0
2"	59.7	56.6	56.0

Thread R ..."

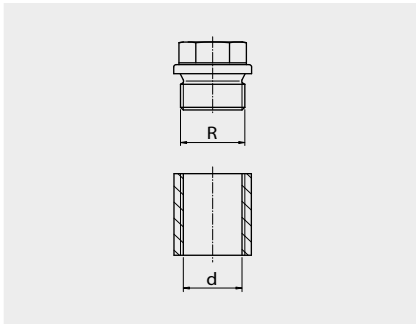

Size	Diameter R [mm]	Core \varnothing d [mm]	Bore [mm]
1/8"	9.7	8.5	8.0
1/4"	13.2	11.4	11.0
3/8"	16.7	14.9	14.5
1/2"	21.0	18.6	18.0
3/4"	26.5	24.1	23.5
1"	33.3	30.2	29.5
1 1/2"	47.8	44.8	44.0
2"	59.7	56.6	56.0

Thread NPT ..."

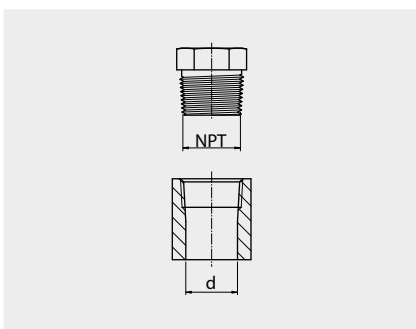

Size	Diameter NPT [mm]	Core \varnothing d [mm]	Bore [mm]
1/8"	9.6	8.4	8.5
1/4"	12.8	11.2	11.0
3/8"	16.2	14.6	14.5
1/2"	19.9	18.2	18.0
3/4"	25.6	23.4	23.0
1"	31.8	29.8	29.0
1 1/2"	46.8	44.2	44.0
2"	58.6	56.4	56.0

Flange Tri - Clamp DIN 32676

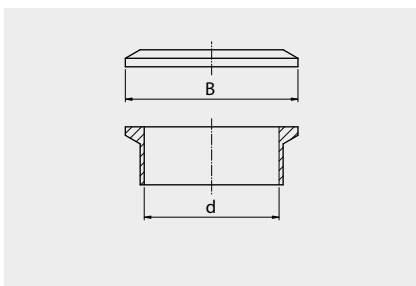

Size	Diameter B [mm]	Inside \varnothing d [mm]	Bore [mm]
DN15	34.0	16.0	15.0
DN20	34.0	20.0	19.0
DN25	50.5	26.0	25.0
DN50	64.0	50.0	48.0
DN65	91.0	66.0	64.0
DN80	106.0	81.0	79.0
DN100	119.0	100.0	98.0

Magnetic Float Switches 1003

Design process connections

Tube connection DIN 11851

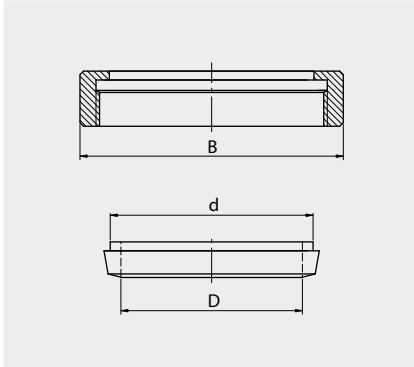

Size	Bore \varnothing d [mm]	Inside \varnothing D [mm]	Union nut B [mm]
DN10	18	10	38
DN15	24	16	44
DN20	30	20	54
DN25	35	26	63
DN40	48	38	78
DN50	61	50	92
DN65	79	66	112
DN80	93	81	127
DN100	114	100	148

Flange DIN 16 bar DIN 2633

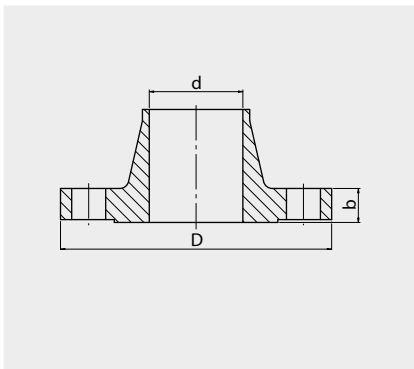

Size	Flange \varnothing D [mm]	Inside \varnothing d [mm]	Flange thickness b [mm]
DN10	90	13.6	14
DN15	95	17.3	14
DN20	105	22.3	16
DN25	115	28.5	16
DN40	150	43.1	16
DN50	165	54.5	18
DN65	185	70.3	18
DN80	200	82.5	20
DN100	220	107.1	20

Flange Ansi 150 lbs B 16.5

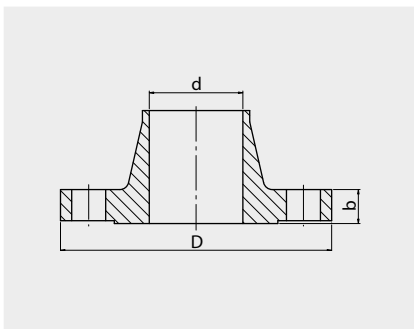

Size	Flange \varnothing D [mm]	Inside \varnothing d [mm]	Flange thickness b [mm]
½"	88.9	15.7	11.2
¾"	98.6	20.8	12.7
1"	108.0	26.7	14.2
1½"	127.0	40.9	17.5
2"	152.4	52.6	19.1
2½"	177.8	62.7	22.4
3"	190.5	78.0	23.9
4"	228.6	102.4	23.9

Magnetic Float Switches 1003

Design process connections

Flange DIN 40 bar DIN 2635

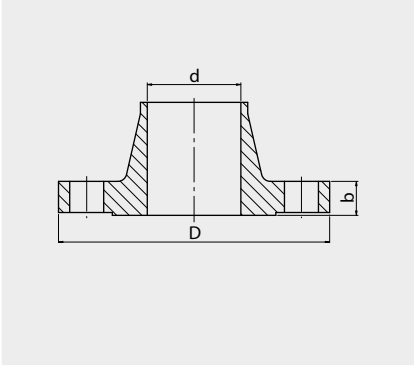

Size	Flange \varnothing D [mm]	Inside \varnothing d [mm]	Flange thickness b [mm]
DN10	90	13.6	16
DN15	95	17.3	16
DN20	105	22.3	18
DN25	115	28.5	18
DN40	150	43.1	18
DN50	165	54.5	20
DN65	185	70.3	22
DN80	200	82.5	24
DN100	235	107.1	24

Flange Ansi 300 lbs B 16.5

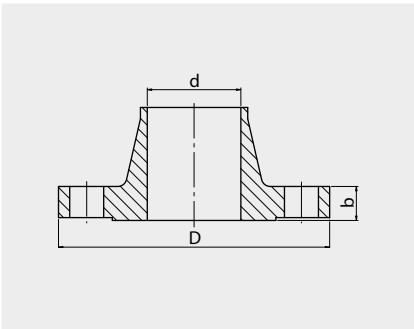

Size	Flange \varnothing D [mm]	Inside \varnothing d [mm]	Flange thickness b [mm]
½"	95.2	15.7	14.2
¾"	117.3	20.8	15.7
1"	124.0	26.7	17.5
1½"	155.4	40.9	20.6
2"	165.1	52.6	22.4
2½"	190.5	62.7	25.4
3"	209.6	78.0	28.4
4"	254.0	102.4	31.8

Magnetic Float Switches 1003

Contact functions / Temperature probe

Contacts	guide tube \varnothing	max. voltage	max. current	switch.capacity
Change over Normally open Normally closed	\varnothing 8 mm \varnothing 8 mm \varnothing 8 mm	150 V DC / AC 150 V DC / AC 150 V DC / AC	0.5 A 0.5 A 0.5 A	10 VA 10 VA 10 VA
Change over Normally open Normally closed	\varnothing 10 ... 40 mm \varnothing 10 ... 40 mm \varnothing 10 ... 40 mm	230 V DC / AC 230 V DC / AC 230 V DC / AC	0.5 A 1 A 1 A	40 VA 100 VA 100 VA
Max. quantity	guide tube \varnothing	change over	normally open	normally closed
	\varnothing 8 mm \varnothing 10 mm \varnothing 12 mm \varnothing 14 mm \varnothing 16 mm \varnothing 18 ... 40 mm	1 2 4 4 5 8	3 3 4 4 6 8	3 3 4 4 6 8
also with hysteresis to 10 mm possible (H)				
Temperature contacts	guide tube \varnothing	max. voltage	max. current	switch.capacity
Normally open Normally closed	\varnothing 8 mm \varnothing 8 mm	- -	- -	- -
Normally open Normally closed	\varnothing 10 ... 40 mm \varnothing 10 ... 40 mm	230V AC/60V DC 230V AC/60V DC	1.0 A 1.0 A	40 VA 40 VA
Max. quantity	guide tube \varnothing		normally open	normally closed
	\varnothing 8 mm \varnothing 10 mm \varnothing 12 mm \varnothing 14 mm \varnothing 16 mm \varnothing 18 ... 40 mm		- 1 2 3 3 6	- 1 2 3 3 6
Measuring accuracy	normally open	normally closed	normally open PEPI	normally closed PEPI
Hysteresis Accuracy Graduation / Resolution Temperature range	7.5 °C +/-5 °C 5 °C 40 °C ... 120 °C	7.5 °C +/-5 °C 5 °C 40 °C ... 120 °C	1 °C +/-3 °C 5 °C 40 °C ... 120 °C	1 °C +/-3 °C 5 °C 40 °C ... 120 °C
Temperature probe	guide tube \varnothing	max. quantity	2/3/4 wire	temp. range
PT- 100 PT- 100 PT-1000 PT-1000	\varnothing 8 mm \varnothing 10 ... 40 mm \varnothing 8 mm \varnothing 10 ... 40 mm	1 5 1 5	2/3 wire 2/3/4 wire 2/3 wire 2/3/4 wire	- 30 °C ... 150 °C - 196 °C ... 250 °C - 30 °C ... 150 °C - 196 °C ... 250 °C

Magnetic Float Switches 1003

Cable / Materials

Cable	Min. / Max. temperature [°C]	Material	Max. leads	Thickness of lead
... PVC -	-20 °C / +80 °C	Polyvinylchloride	12	0.25 - 0.75
... PVC-blau -	-20 °C / +80 °C	Polyvinylchloride	7	0.75
... Sil -	-60 °C / +180 °C	Silicone	12	0.25 - 0.75
... PUR -	-40 °C / +80 °C	Polyurethane	10	0.25 - 0.75
... FEP -	-100 °C / +200 °C	Fluorethylenpropylene	4	0.25 - 0.5
... Radox -	-35 °C / +120 °C	Radox	10	0.5 - 0.75
... Lit -	-5 °C / +70 °C -65 °C / +200 °C	Insulated stranded wires PVC Insulated stranded wires FEP	1 1	0.5 0.5
... NiLit -	-60 °C / +450 °C	Insulated nickel stranded wires with glass insulation	1	0.5

Options

... / CY	Shielded cable
... / ÖL	Oil resisting cable

Material design temperatures	Material	Temperature min.	Temperature max.
V	Stainless steel	- 196 °C	+ 400 °C
Ti	Titanium	- 10 °C	+ 300 °C
H	Alloy / Ni Mo	- 196 °C	+ 400 °C
EEC	Stainless steel E-CTFE coated	- 78 °C	+ 150 °C
PFA	Stainless steel PFA coated	- 100 °C	+ 250 °C
P	Polyvinylchloride PVC	- 15 °C	+ 60 °C
PP	Polypropylene PP	- 5 °C	+ 80 °C
PF	Polyvinylidenfluoride PVDF	- 5 °C	+ 150 °C
PA	Polyamide PA	- 40 °C	+ 110 °C
M	Brass	- 196 °C	+ 250 °C
AL	Aluminium	- 196 °C	+ 150 °C
R	Gunmetal	-196 °C	+150 °C