

Suspended Float Switches 1009

Suspended Float Switches 1009

Table of contents

Index

Table of contents	164
Description and function	165-166
Level Controller MS1 / MS1 electronic Ex	167
Level Controller M2 / M3	168
Type key	169

Suspended Float Switches 1009

Description and function

Safe level controllers with a compound-filled encapsulated Hg control element

These level controllers will operate in a consistent and reliable manner for many years with a fully encapsulated switching element to protect the environment. There are no external moving parts and within the unit, the contacts switch in an inert gas atmosphere without contact bounce. They can also take a high surge current and are therefore superior to mechanically operated switches for current capacity and number of switching operations.

The Hg control elements contain a minimal amount of mercury (approx. 0.08cm^3) and are housed in a compound-filled encapsulation to make them shock and shatter-proof. This encapsulation is liquid and gas tight for environmental safety.

Switching currents can range from 1 mA. to 2 A. with surge currents up to 5 A. making them able to directly control contactors or to switch extremely small



currents in an electronic circuit. Voltage ranges are from 4 to 250 volts.

The level controller MS 1 Electronic Ex corresponds to the latest requirements of the directive 94/9/EG (ATEX) for operation within areas with explosive atmospheres. In accordance with the approval ASEV 99.1 10036.01, this level controller, with an intrinsically safe circuit, may be used in the Ex-zones 0, 1 and 2 as well as in the gas groups IIA, IIB and IIC, which are highly combustible materials in the temperature class T6. Thanks to the good chemical and thermal properties of the completely water-proof polypropylene housing and the special high-grade, cold flex resistant TPK/PVC cable, our level controllers are resistant to

sediment, uric acid, faecal sewage water, oils, petrol, diesel oil, alcohol, fruit acids and many other chemicals.

Level Controller MS1

Designed specially for use in sewage works and pumping stations with liquids heavily charged with solid matter such as raw sewage etc.

The level controller is freely suspended from a highly flexible, heavy-duty cable and set at the required level. As the water level rises and falls, the angular position of the level sensor changes to operate the switch. One controller is required for each switching level but as the switches are change over switches, the controller can be used to either empty or fill a tank or to trigger an alarm.

The switching element is housed in a dual-sealed chamber making it both water-proof and rupture-proof.

The practical "drop" shape, built-in stabilising weight and the smooth non-porous surface make the level controller buoyant in a stable manner with resistance to turbulence and solid matter sticking to the surface. In addition to being mechanically sealed and equipped with a solid strain relief, the cable entry is completely filled with a synthetic resin compound poured into a separate chamber thus ensuring that no moisture can penetrate the electrical connecting area.

Switching currents can range from 1 mA. to 5 A. making them able to directly control contactors or to switch extremely small currents in an electronic circuit. Voltages range from 4 to 250 volts.

Suspended Float Switches 1009

Description and function

Level Controller MS1 electronic EX

The level controller MS 1 Electronic Ex corresponds to the latest requirements of the directive 94/9/EG (ATEX) for operation within areas with explosive atmospheres. In accordance with the approval ASEV 99.1 10036, this

level controller, with an intrinsically safe circuit, may be used in the Ex zones 0, 1 and 2 as well as in the gas groups IIA, IIB and IIC, where there is an explosion hazard due to combustible materials in temp. class T6.

Level Controller M2

Due to its small volume and consequently less buoyancy, this "small" level controller is more suitable for use in media with lower amount of solids or in smaller tanks with limited space. Unlike the level controller MS 1, this controller must be fixed at the switching level with a

cable-weight (see page 162 type M3) as there is no in-built stabilising weight. This level controller is supplied with a change over contact to allow either a filling or emptying function. Its other properties are the same as the model MS 1.

Level Controller M3 with cable weight

Due to its small diameter of only 40mm, this level controller can be installed through a 2" thread and the switching point can be fixed by means of the cable weight. Its other properties are the same as the model M 2.

Suspended Float Switches 1009

Level Controller MS1 / MS1 electronic Ex

Technical data	MS1- .. TPK
Float material:	Polypropylene
Cable material:	TPK Thermoplastic
Contact function:	Change over 1.0 mA / 4.0 V 5.0 A / 250.0 V
Specific gravity:	950 ... 1050 kg/m ³
Operating temperature max.:	80 °C
Switching angle:	10°
Protection rating:	IP68
Cable cross section:	3.0 x 1.0 mm ²
Dimension:	180 x 100 mm
Cable length:	5 m / 10 m / 20 m
Housing colour:	Orange
Cable colour:	Orange

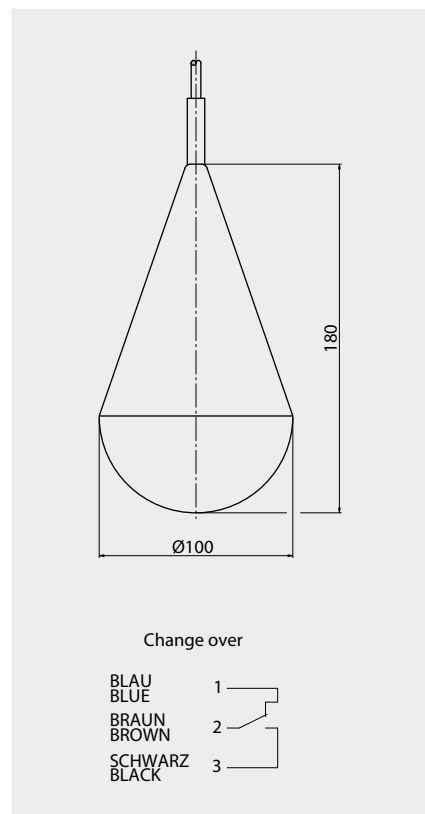

Technical data	MS1- .. TPK - Ex
Float material:	Polypropylene conductive
Cable material:	TPK conductive Thermoplastic
Contact function:	Change over 1.0 ... 100.0 mA 4.0 ... 40.0 V
Specific gravity:	950 ... 1050 kg/m ³
Operating temperature max.:	80 °C
Switching angle:	10°
Protection rating:	IP68
Cable cross section:	3.0 x 0.75 mm ²
Dimension:	180 x 100 mm
Cable length:	5 m / 10 m / 20 m
Housing colour:	Black
Cable colour:	Blue
Approval:	ATEX 94/9/EG EExia T6

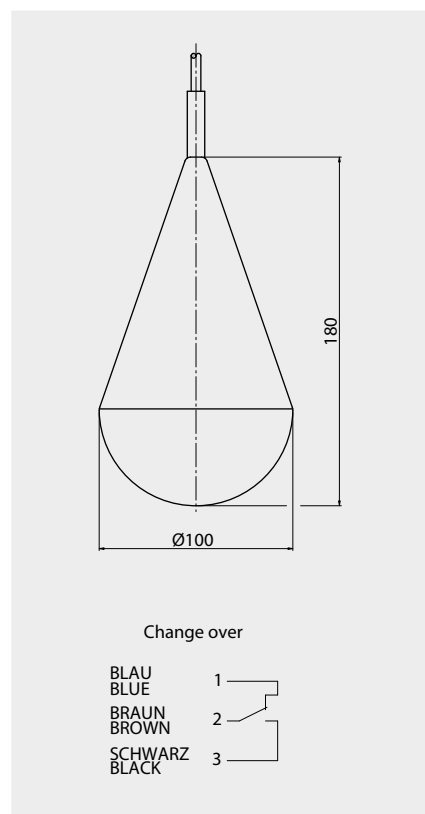

Type combination see type key Suspended Float Switches

Suspended Float Switches 1009

Level Controller M2 / M3

Technical data	M2- .. TPK
Float material:	Polypropylene
Cable material:	TPK Thermoplastic
Contact function:	Change over 1.0 mA / 4.0 V 2 A / 250.0 V
Specific gravity:	950 ... 1050 kg/m ³
Operating temperature max.:	80 °C
Switching angle:	10°
Protection rating:	IP68
Cable cross section:	3.0 x 0.5 mm ²
Dimension:	90 x 60 mm
Cable length:	5 m / 10 m / 20 m
Housing colour:	Orange
Cable colour:	Orange

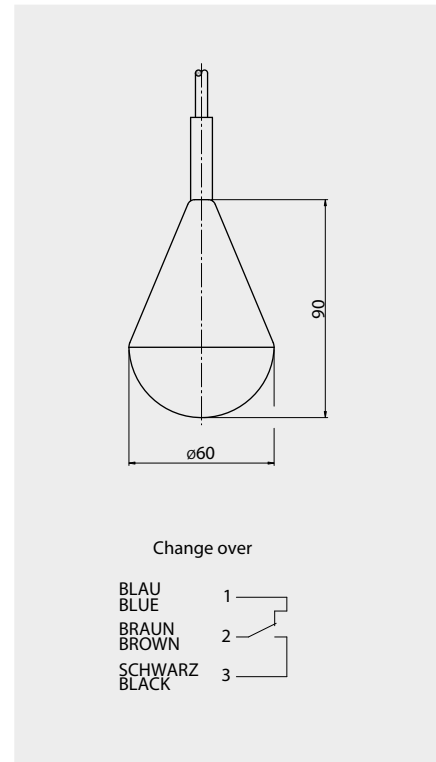



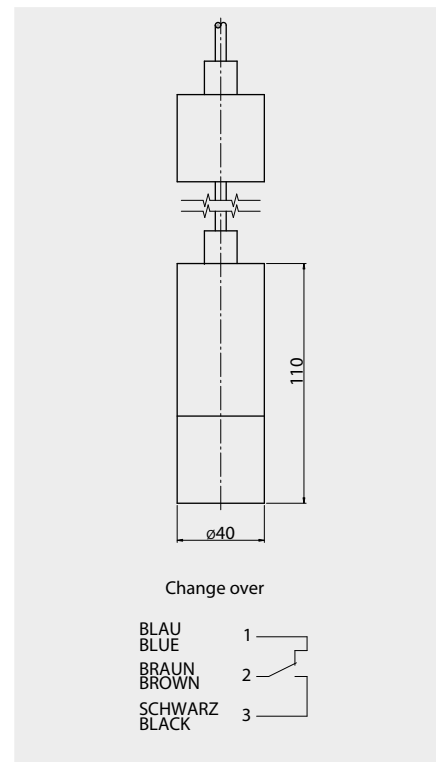

Technical data	M3- .. TPK
Float material:	Polypropylene
Cable material:	TPK Thermoplastic
Contact function:	Change over 1.0 mA / 4.0 V 2 A / 250.0 V
Specific gravity:	950 ... 1050 kg/m ³
Operating temperature max.:	80 °C
Switching angle:	10°
Protection rating:	IP68
Cable cross section:	3.0 x 0.5 mm ²
Dimension:	110 x 40 mm
Cable length:	5 m / 10 m / 20 m
Housing colour:	Orange
Cable colour:	Orange



Type combination see type key Suspended Float Switches

Suspended Float Switches 1009

Type key

Code 1	Key 1	Shape of housing	ATEX
	MS1 -	Housing 180.0 x 100.0 mm	
	M2 -	Housing 90.0 x 60.0 mm	
	M3 -	Housing 110.0 x 40.0 mm	
	... -	Various	
Code 2	Key 1	Cable length	ATEX
	5 TPK	5m connection cable TPK (thermoplastic)	
	10 TPK	10m connection cable TPK (thermoplastic)	
	20 TPK	20m connection cable TPK (thermoplastic)	
	... -	Various	
Code 3	Key 1	Approvals	ATEX
	Ex	ATEX EExia	
	...	Various	

Type combination

Code	1	2	3
Key	1	1	1
Example	MS1	- 10TPK	Ex